

### Features

- For Switching and Amplifier Applications.
- As Complementary Type of the PNP Transistor PXT8550-53 is Recommended.

### Equivalent Circuit

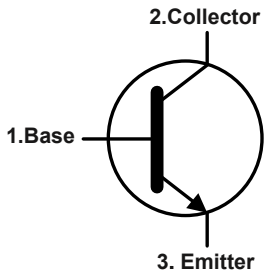

### SOT-89

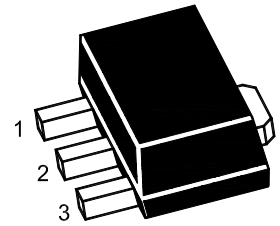

1.Base 2.Collector 3. Emitter

Marking Code : Y1

### Absolute Maximum Ratings

Ratings at 25°C ambient temperature unless otherwise specified.

Parameter	Symbol	Value	Unit
Collector Base Voltage	$V_{CB0}$	40	V
Collector Emitter Voltage	$V_{CEO}$	25	V
Emitter Base Voltage	$V_{EBO}$	6	V
Collector Current	$I_c$	1.5	A
Maximum Power Dissipation	$P_D$	1	W
Junction Temperature	$T_J$	150	°C
Storage Temperature Range	$T_{STG}$	-55 to +150	°C



**Electrical Characteristics (T<sub>A</sub>=25°C)**

Parameter	Symbol	Min.	Max.	Unit
DC Current Gain at V <sub>CE</sub> = 1 V, I <sub>C</sub> = 100 mA at V <sub>CE</sub> = 1 V, I <sub>C</sub> = 800 mA	H <sub>FE</sub>	200 40	320 --	--
Collector Base Cutoff Current at V <sub>CB</sub> = 40 V	I <sub>CBO</sub>	--	100	nA
Collector Base Breakdown Voltage at I <sub>C</sub> = 100 μA	V <sub>(BR)CBO</sub>	40	--	V
Collector Emitter Breakdown Voltage at I <sub>C</sub> = 0.1 mA	V <sub>(BR)CEO</sub>	25	--	V
Emitter Base Breakdown Voltage at I <sub>E</sub> = 100 μA	V <sub>(BR)EBO</sub>	6	--	V
Collector Emitter Saturation Voltage at I <sub>C</sub> = 800 mA, I <sub>B</sub> = 80 mA	V <sub>CE(sat)</sub>	--	0.5	V
Base Emitter Saturation Voltage at I <sub>C</sub> = 800 mA, I <sub>B</sub> = 80 mA	V <sub>BE(sat)</sub>	--	1.2	V
Transition Frequency at V <sub>CE</sub> = 10 V, I <sub>C</sub> = 50 mA, f=30MHz	f <sub>T</sub>	150	--	MHz

### Typical Characteristic Curves

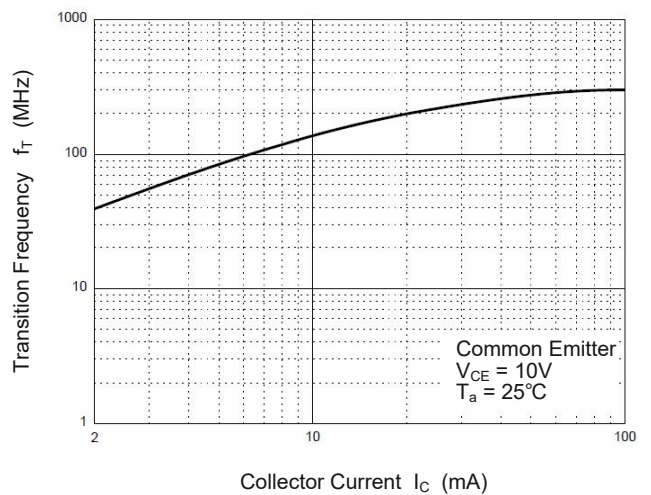
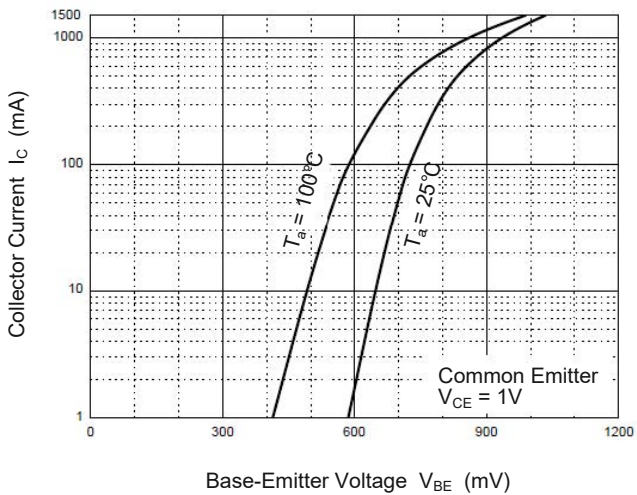
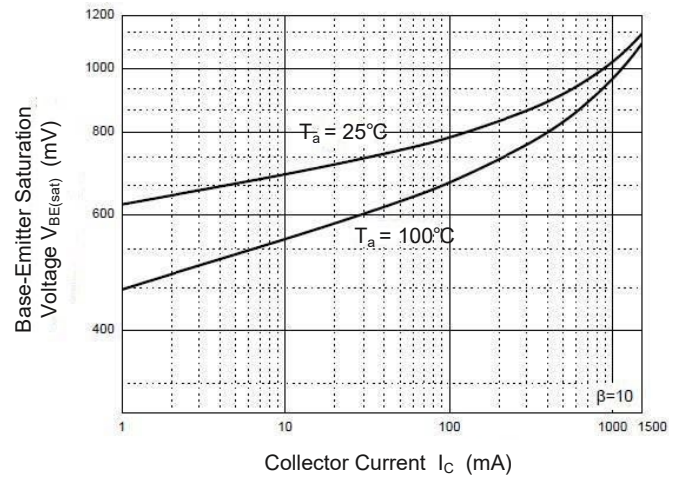
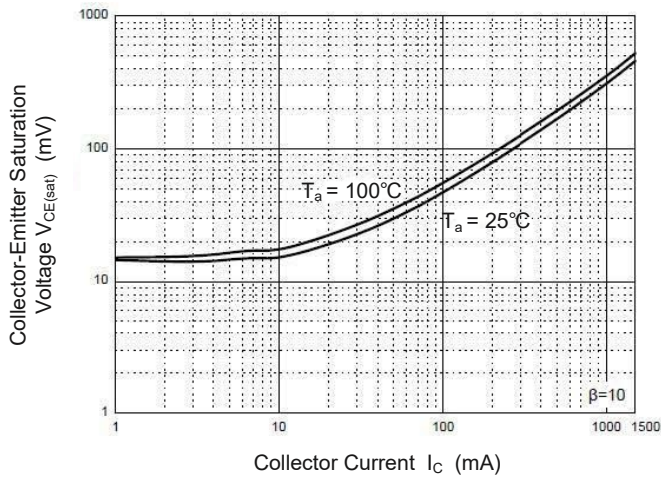
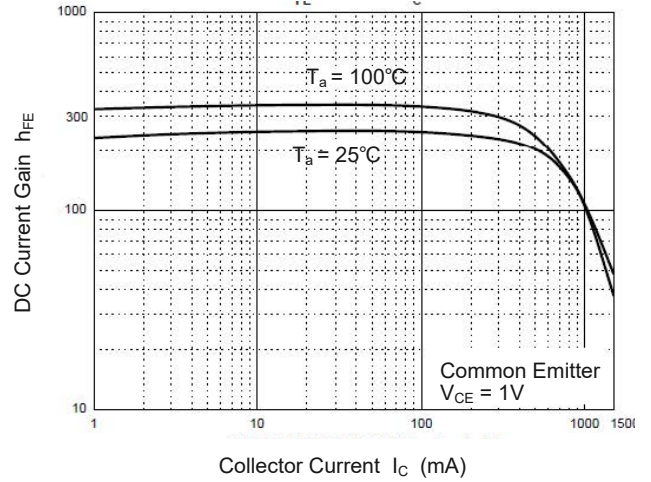
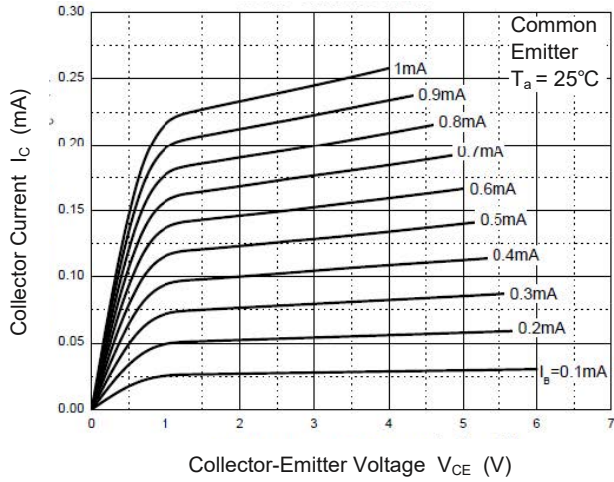

### Package Outline

SOT-89

Dimensions in mm

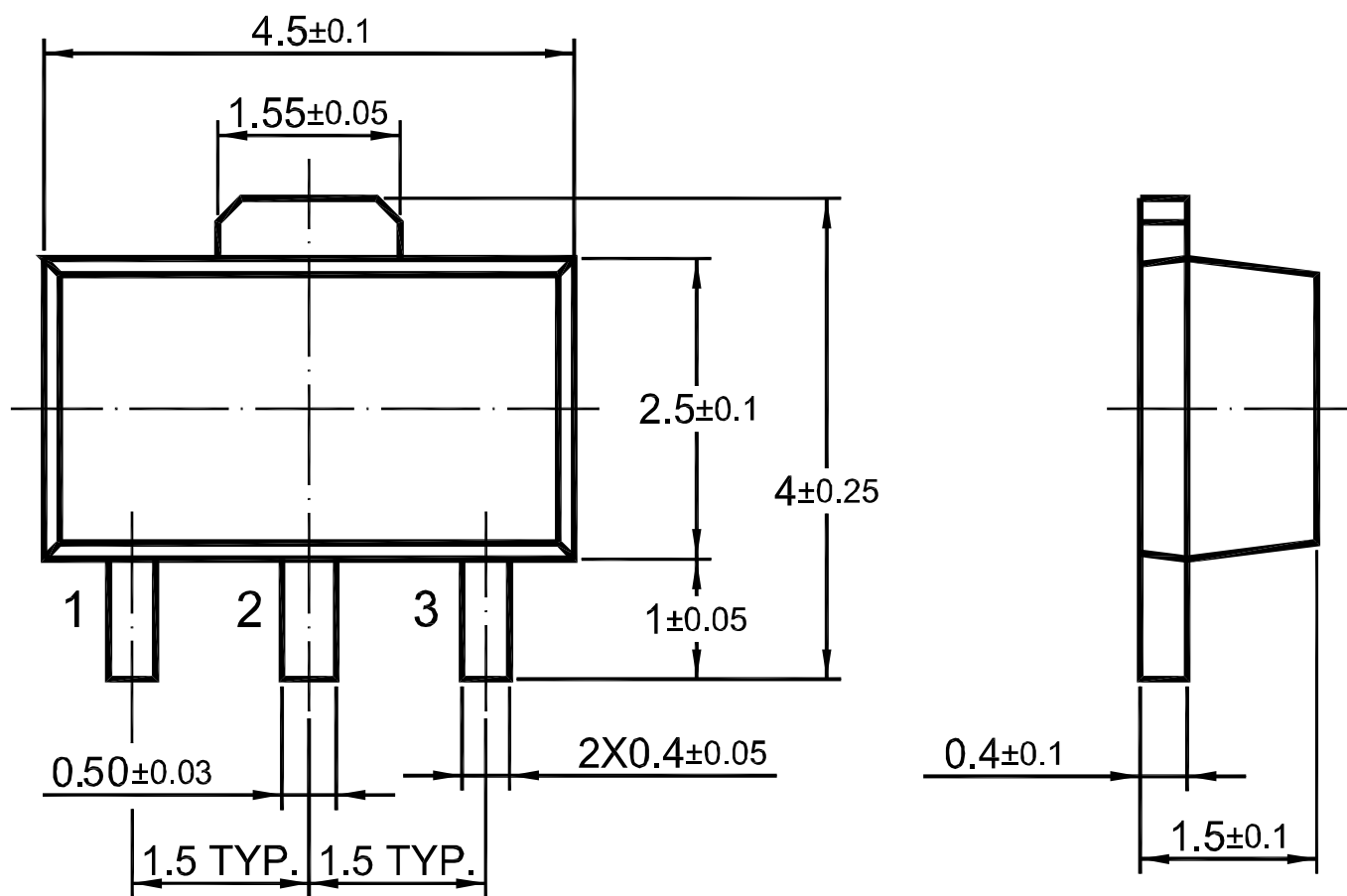

### Ordering Information

Device	Package	Shipping
PXT8050-53	SOT-89	1,000PCS/Reel&7inches
		3,000PCS/Reel&13inches

### Conditions of Soldering and Storage

#### ◆ Recommended condition of reflow soldering



Recommended peak temperature is over 245 °C. If peak temperature is below 245 °C, you may adjust the following parameters:

- Time length of peak temperature (longer)
- Time length of soldering (longer)
- Thickness of solder paste (thicker)

#### ◆ Conditions of hand soldering

- Temperature: 370 °C
- Time: 3s max.
- Times: one time

#### ◆ Storage conditions

- **Temperature**  
5 to 40 °C
- **Humidity**  
30 to 80% RH
- **Recommended period**  
One year after manufacturing

### Package Specifications

- The method of packaging (1,000PCS/Reel&7inches)

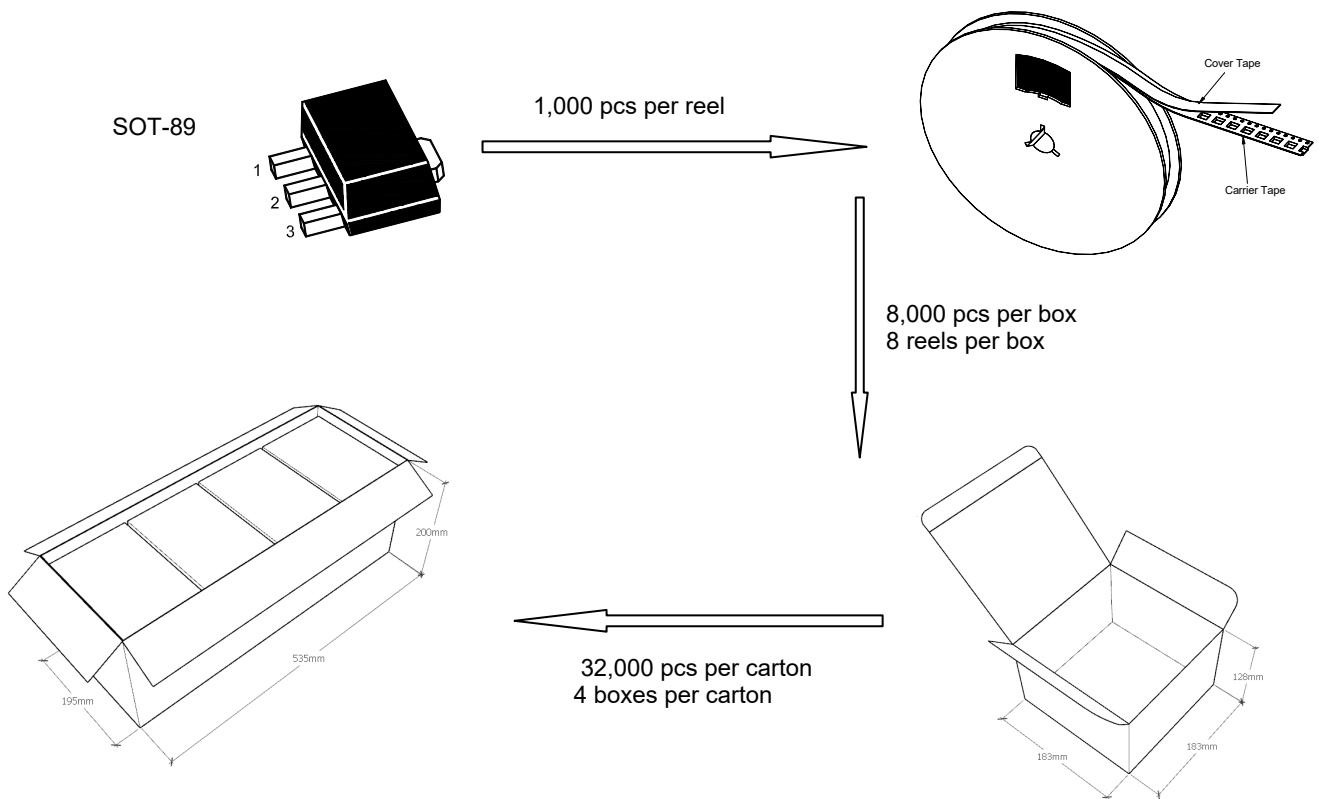

### ◆ Embossed tape and reel data

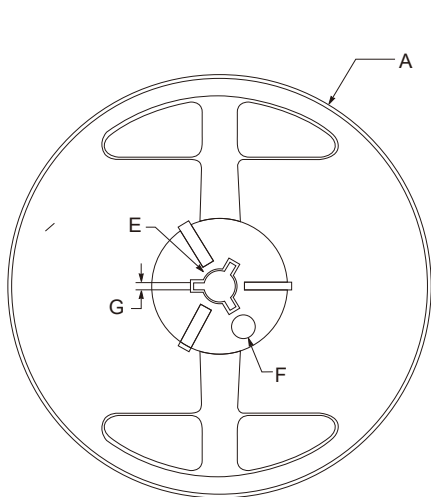

Reel (7")

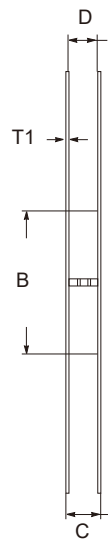

symbol	Value(unit:mm)
A	$\Phi 179 \pm 1$
B	60.5 $\pm$ 0.2
C	15.3 $\pm$ 0.3
D	12.5~13.7
E	$\Phi 13.5 \pm 0.2$
F	$\Phi 10.0 \pm 0.2$
G	2.7 $\pm$ 0.2
T1	1.0 $\pm$ 0.2

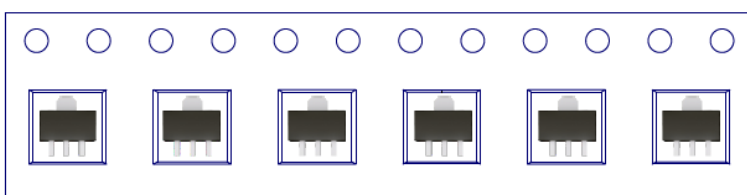

### Package Specifications

- The method of packaging (3,000PCS/Reel&13inches)

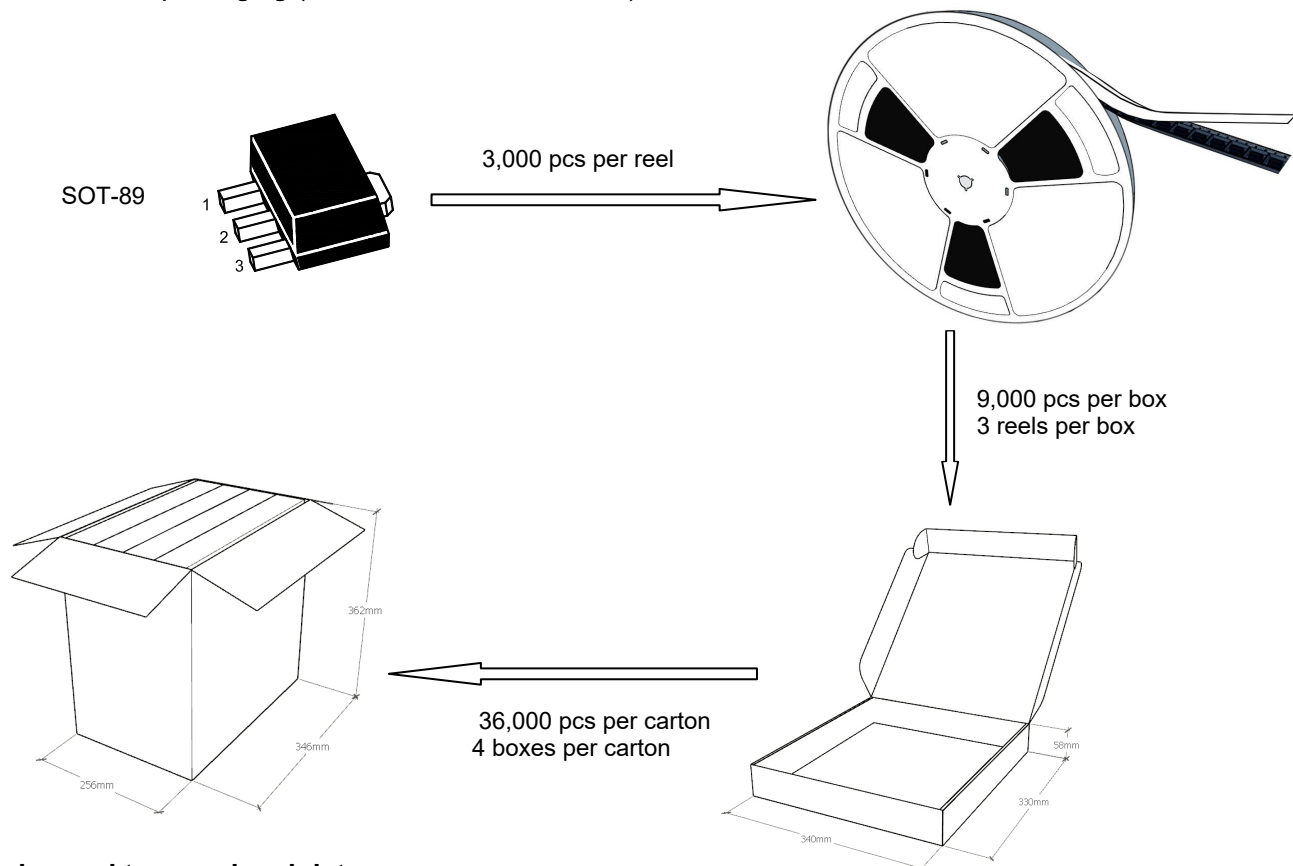

### ◆ Embossed tape and reel data



symbol	Value(unit:mm)
A	$\Phi 330 \pm 1$
B	$12.7 \pm 0.5$
C	$16.5 \pm 0.3$
D	$\Phi 99.5 \pm 0.5$
E	$\Phi 13.6 \pm 0.3$
F	$2.8 \pm 0.3$
T1	$1.9 \pm 0.2$

