



# PJM2301PSA

## P-Channel Enhancement Mode Power MOSFET

### Features

- Surface mount package
- Halogen free product is acquired
- High power and current handling capability
- $V_{DS} = -20V, I_D = -2.8A$   
 $R_{DS(on)} < 110m\Omega @ V_{GS} = -4.5V$

### SOT-23

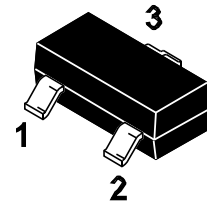

1. Gate 2. Source 3. Drain

Marking Code: M01

### Applications

- Battery protection
- Load switch
- Power management

### Schematic Diagram

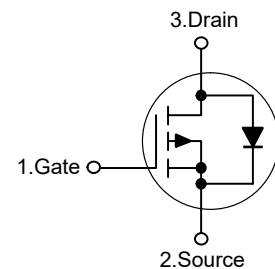

### Absolute Maximum Ratings

Ratings at 25°C ambient temperature unless otherwise specified.

Parameter	Symbol	Value	Unit
Drain-Source Voltage	$-V_{DS}$	20	V
Gate-Source Voltage	$V_{GS}$	$\pm 12$	V
Drain Current-Continuous	$-I_D$	2.8	A
Drain Current-Pulsed <sup>Note1</sup>	$-I_{DM}$	10	A
Maximum Power Dissipation	$P_D$	0.7	W
Junction Temperature	$T_J$	150	°C
Storage Temperature Range	$T_{STG}$	-55 to +150	°C

### Thermal Characteristics

Thermal Resistance, Junction-to-Ambient <sup>Note2</sup>	$R_{\theta JA}$	179	°C/W
--	-----------------	-----	------



# PJM2301PSA

## P-Channel Enhancement Mode Power MOSFET

### Electrical Characteristics

(Ta=25°C unless otherwise specified)

Parameter	Symbol	Test Condition	Min.	Typ.	Max.	Unit
<b>Static Characteristics</b>						
Drain-Source Breakdown Voltage	$-V_{(BR)DSS}$	$V_{GS}=0V, I_D=-250\mu A$	20	--	--	V
Zero Gate Voltage Drain Current	$-I_{DSS}$	$V_{DS}=-20V, V_{GS}=0V$	--	--	1	$\mu A$
Gate-Body Leakage Current	$I_{GSS}$	$V_{GS}=\pm 8V, V_{DS}=0V$	--	--	$\pm 100$	nA
Gate Threshold Voltage <sup>Note3</sup>	$-V_{GS(th)}$	$V_{DS}=V_{GS}, I_D=-250\mu A$	0.4	0.7	1	V
Drain-Source On-Resistance <sup>Note3</sup>	$R_{DS(on)}$	$V_{GS}=-4.5V, I_D=-2.8A$	--	78	110	m $\Omega$
		$V_{GS}=-2.5V, I_D=-2A$	--	102	140	m $\Omega$
Forward Transconductance <sup>Note3</sup>	$g_{FS}$	$V_{DS}=-5V, I_D=-2.8A$	--	2	--	S
<b>Dynamic Characteristics</b>						
Input Capacitance	$C_{iss}$	$V_{DS}=-10V, V_{GS}=0V, f=1MHz$	--	325	--	pF
Output Capacitance	$C_{oss}$		--	63	--	pF
Reverse Transfer Capacitance	$C_{rss}$		--	37	--	pF
<b>Switching Characteristics</b>						
Turn-on Delay Time	$t_{d(on)}$	$V_{DD}=-10V, R_L=5\Omega, V_{GS}=-4.5V, R_{GEN}=3\Omega$	--	11	--	nS
Turn-on Rise Time	$t_r$		--	5.5	--	nS
Turn-off Delay Time	$t_{d(off)}$		--	22	--	nS
Turn-off Fall Time	$t_f$		--	8	--	nS
Total Gate Charge	$Q_g$	$V_{DS}=-10V, I_D=-2A, V_{GS}=-4.5V$	--	3.2	--	nC
Gate-Source Charge	$Q_{gs}$		--	0.6	--	nC
Gate-Drain Charge	$Q_{gd}$		--	0.9	--	nC
<b>Source-Drain Diode Characteristics</b>						
Diode Forward Voltage <sup>Note3</sup>	$-V_{SD}$	$V_{GS}=0V, I_S=-2.8A$	--	--	1.2	V
Diode Forward Current <sup>Note2</sup>	$-I_S$		--	--	2.8	A

- Note: 1. Repetitive Rating: Pulse width limited by maximum junction temperature.  
 2. Surface Mounted on FR4 Board,  $t \leq 10$  sec.  
 3. Pulse Test: Pulse width  $\leq 300\mu s$ , duty cycle  $\leq 2\%$ .



# PJM2301PSA P-Channel Enhancement Mode Power MOSFET

## Typical Characteristic Curves

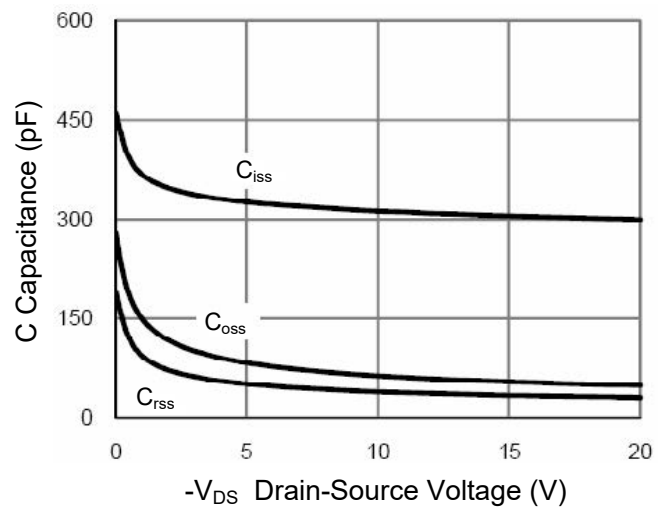
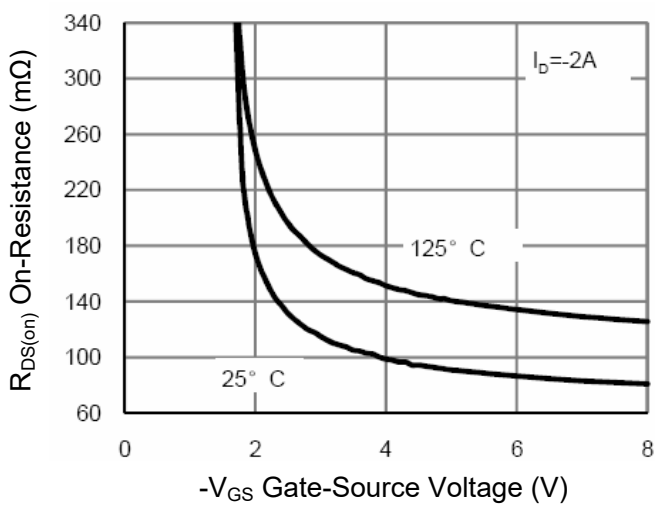
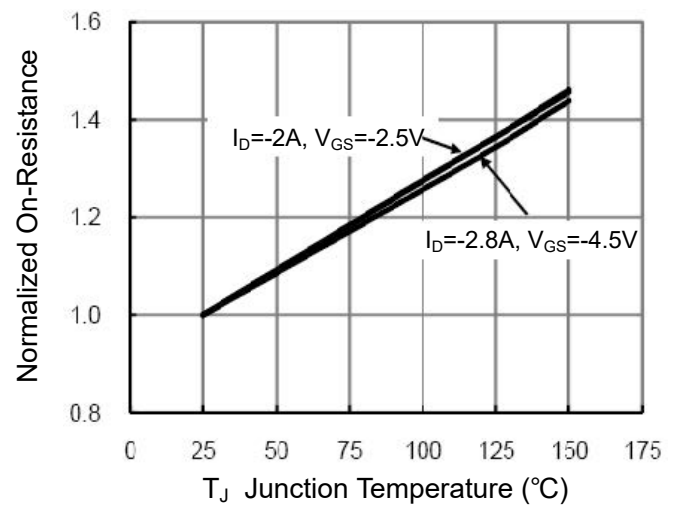
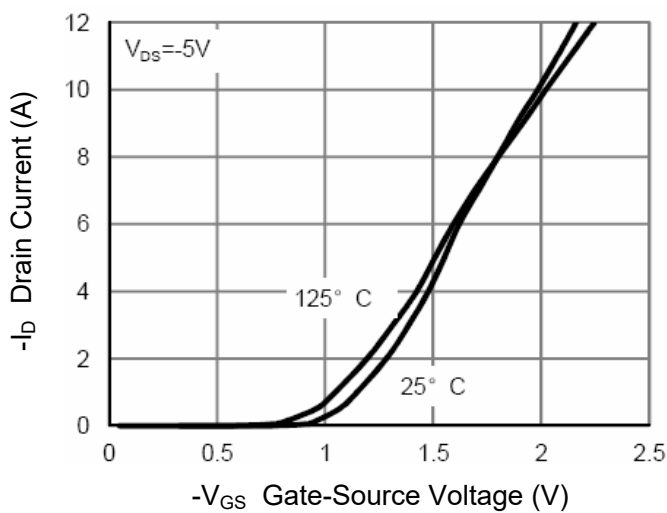
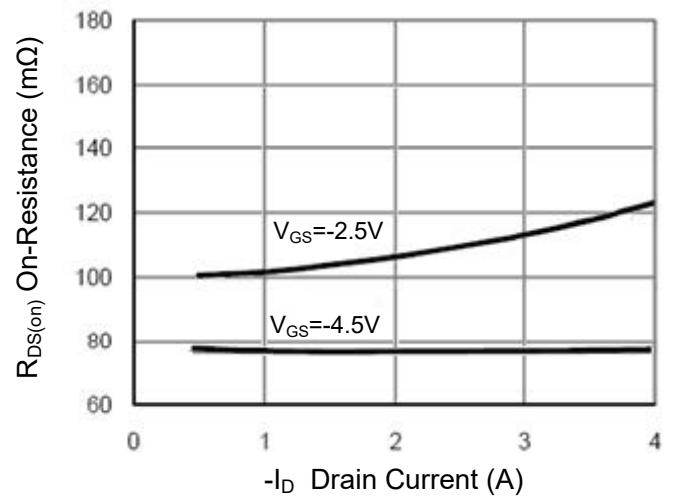
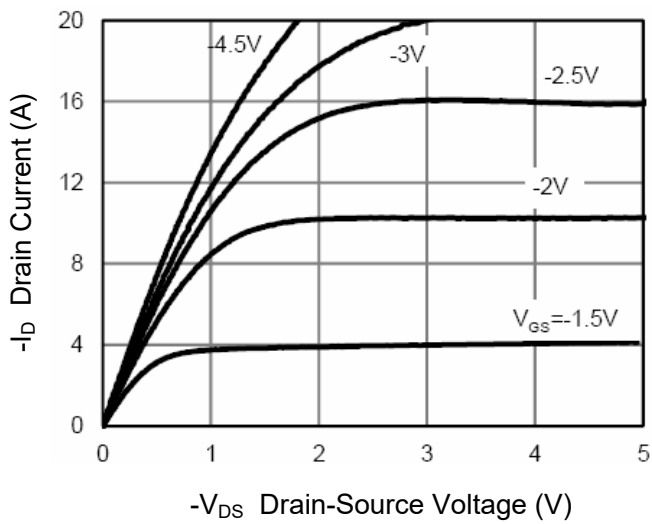



# PJM2301PSA P-Channel Enhancement Mode Power MOSFET

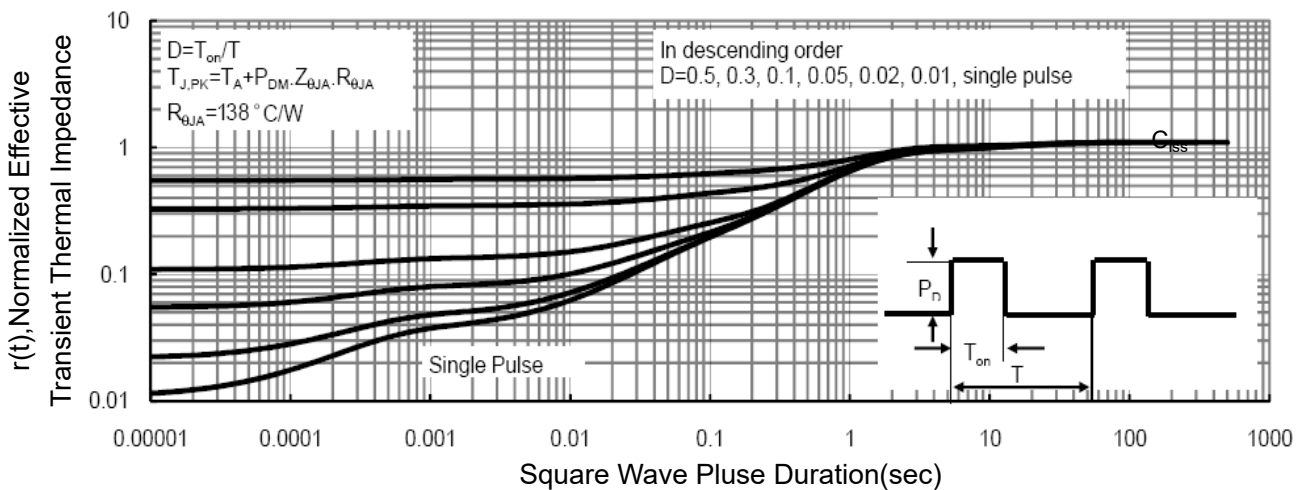
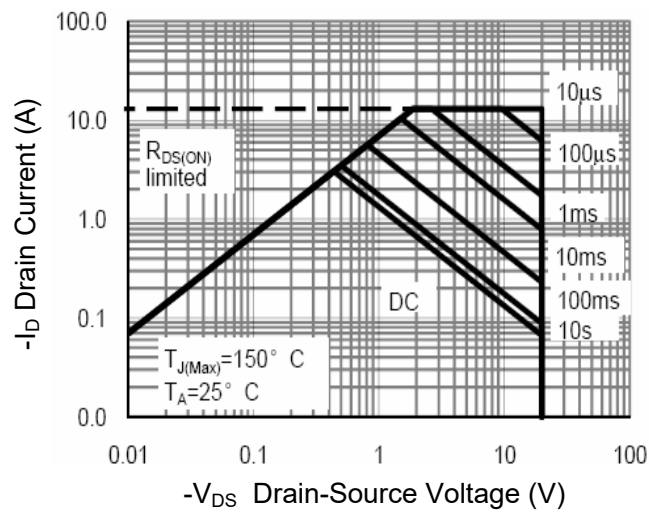
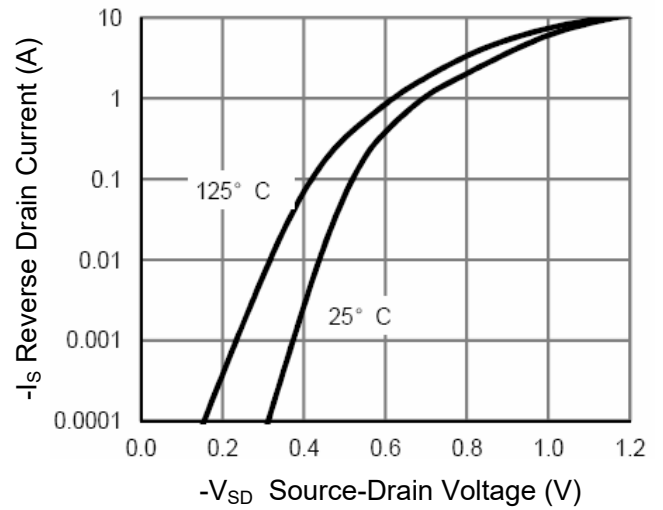
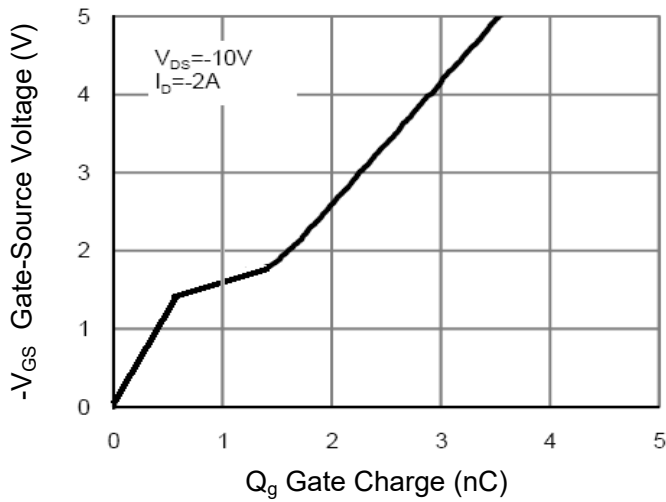



# PJM2301PSA

## P-Channel Enhancement Mode Power MOSFET

### Package Outline

SOT-23

Dimensions in mm

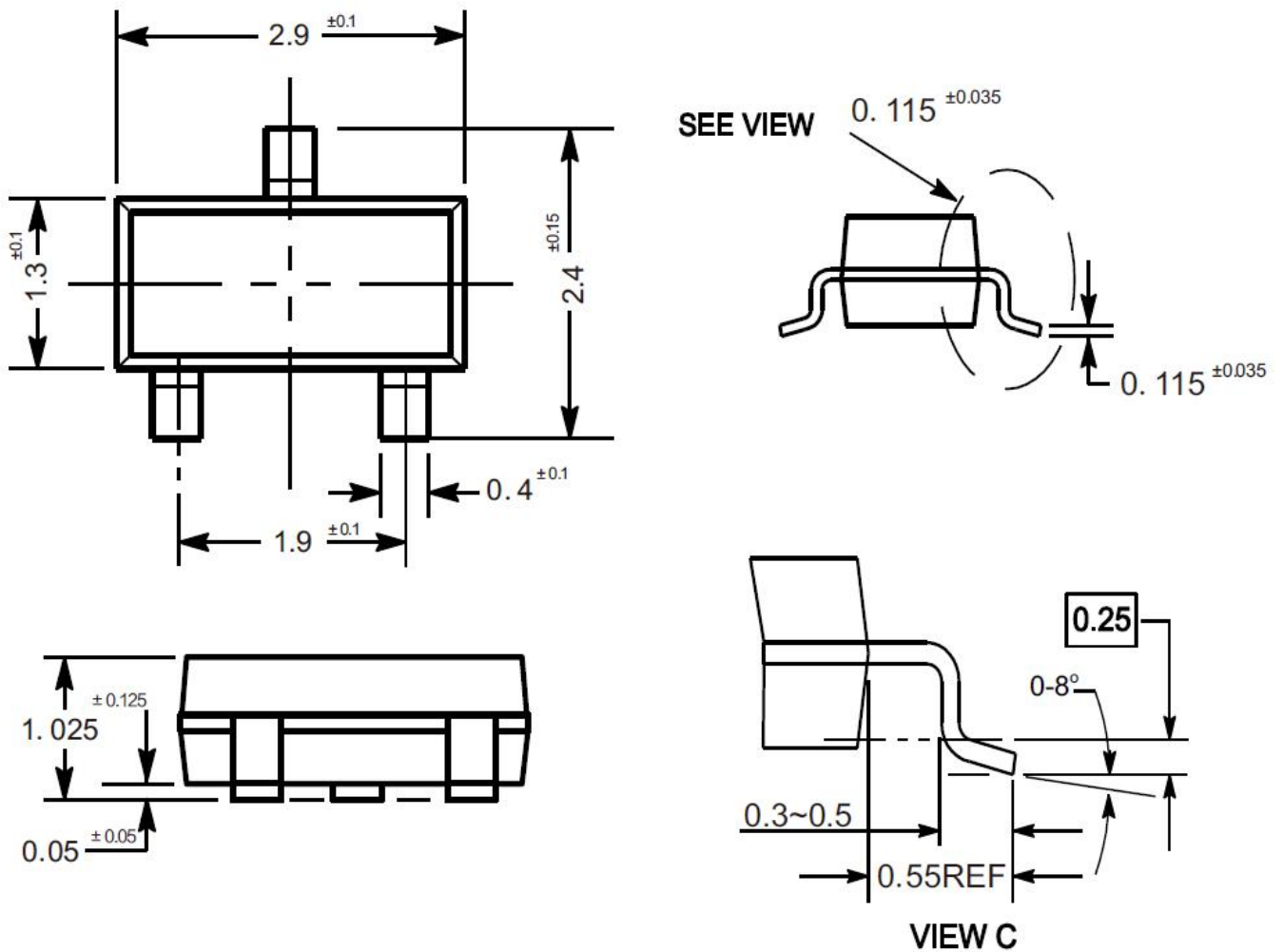

### Ordering Information

Device	Package	Shipping
PJM2301PSA	SOT-23	3,000PCS/Reel&7inches



### Conditions of Soldering and Storage

#### ◆ Recommended condition of reflow soldering

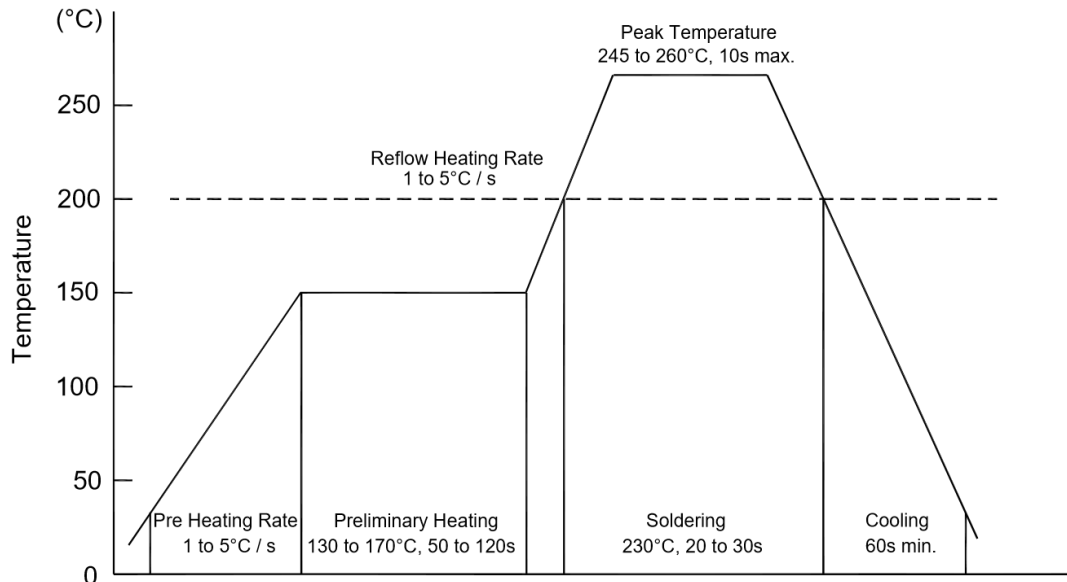

Recommended peak temperature is over 245 °C. If peak temperature is below 245 °C, you may adjust the following parameters:

- Time length of peak temperature (longer)
- Time length of soldering (longer)
- Thickness of solder paste (thicker)

#### ◆ Conditions of hand soldering

- Temperature: 370 °C
- Time: 3s max.
- Times: one time

#### ◆ Storage conditions

- **Temperature**  
5 to 40 °C
- **Humidity**  
30 to 80% RH
- **Recommended period**  
One year after manufacturing

### Package Specifications

- The method of packaging

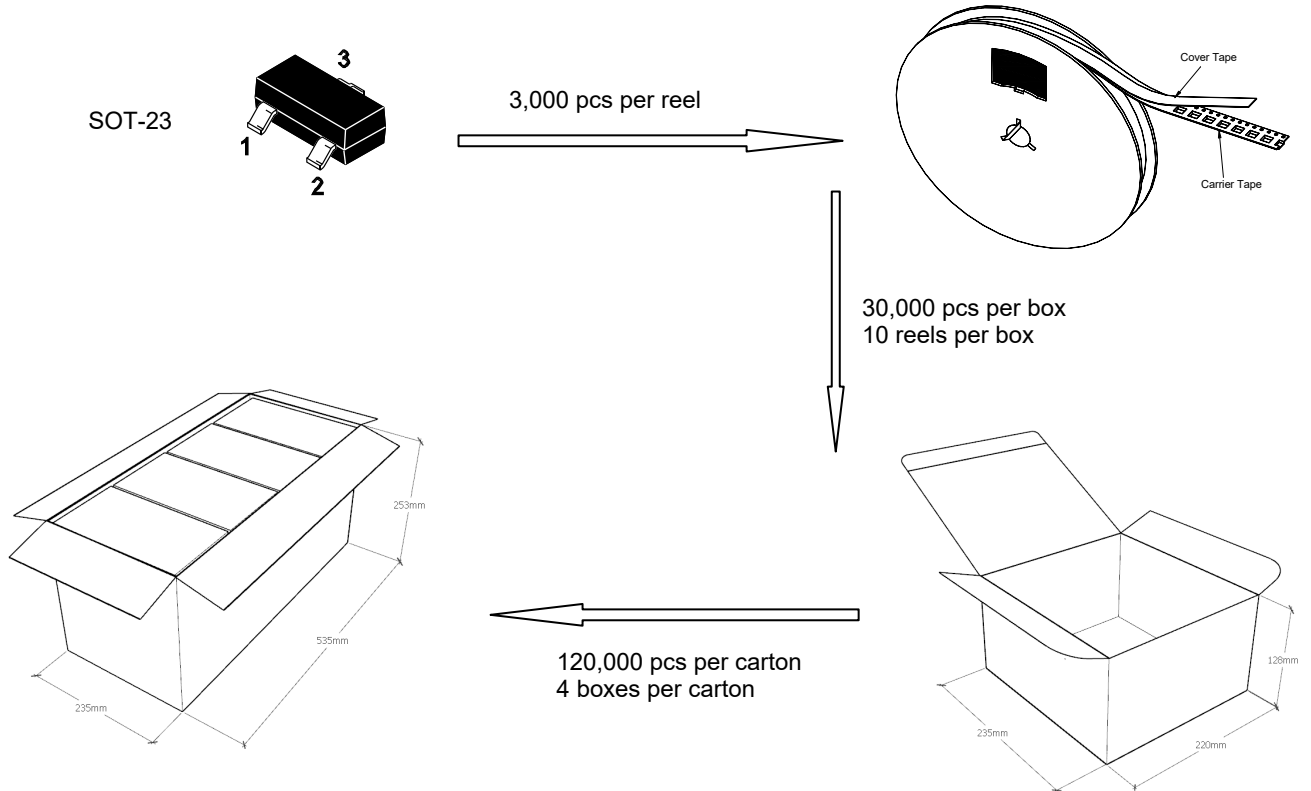

### ◆ Embossed tape and reel data

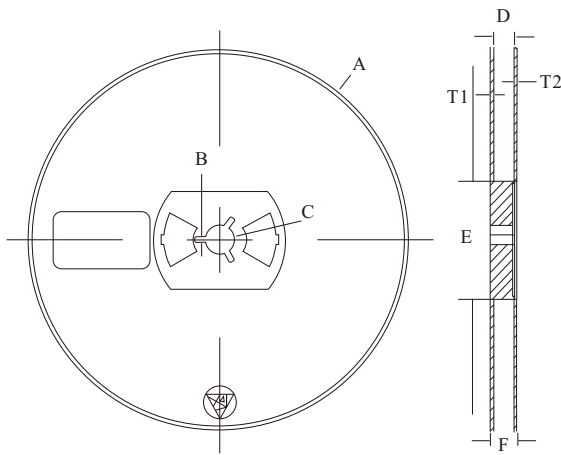

Symbol	Value (unit: mm)
A	Ø 177.8±1
B	2.7±0.2
C	Ø 13.5±0.2
E	Ø 54.5±0.2
F	12.3±0.3
D	9.6+2/-0.3
T1	1.0±0.2
T2	1.2±0.2

Reel (7")

