



PJM15P60DL

P-Channel Enhancement Mode Power MOSFET

Features

- Excellent $R_{DS(ON)}$ and Low Gate Charge
- $V_{DS} = -60V, I_D = -15A$
 $R_{DS(on)} < 85m\Omega @ V_{GS} = -10V$

PDFN3x3-8L

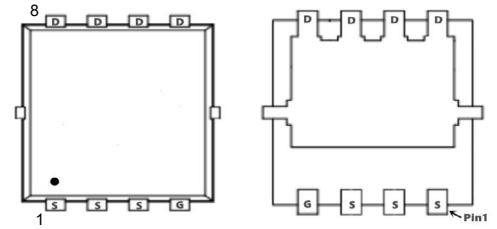

Applications

- Brushless motor
- Load switch
- Mobile phone fast charging

Schematic Diagram

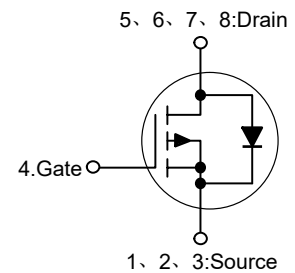

Absolute Maximum Ratings

Ratings at 25°C Case temperature unless otherwise specified.

Parameter	Symbol	Value	Unit
Drain-Source Voltage	$-V_{DS}$	60	V
Gate-Source Voltage	V_{GS}	± 20	V
Drain Current-Continuous and $V_{GS} = 10V$ ^{Note1}	$-I_D$	15	A
Drain Current-Pulsed ^{Note2}	$-I_{DM}$	30	A
Single Pulse Avalanche Energy ^{Note3}	E_{AS}	29.8	mJ
Maximum Power Dissipation ^{Note4}	P_D	31.3	W
Junction Temperature	T_J	150	°C
Storage Temperature Range	T_{STG}	-55 to +150	°C

Thermal Characteristics

Thermal Resistance, Junction-to-Ambient ^{Note1}	$R_{\theta JA}$	25	°C/W
Thermal Resistance, Junction-to-Case ^{Note1}	$R_{\theta JC}$	4	°C/W

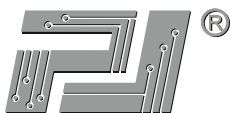

PJM15P60DL

P-Channel Enhancement Mode Power MOSFET

Electrical Characteristics

(T_J=25°C unless otherwise specified)

Parameter	Symbol	Test Condition	Min.	Typ.	Max.	Unit
Static Characteristics						
Drain-Source Breakdown Voltage	-V _{(BR)DSS}	V _{GS} =0V, I _D =-250μA	60	--	--	V
Zero Gate Voltage Drain Current	-I _{DSS}	V _{DS} =-48V, V _{GS} =0V	--	--	1	μA
Gate-Body Leakage Current	I _{GSS}	V _{GS} =±20V, V _{DS} =0V	--	--	±100	nA
Gate Threshold Voltage ^{Note2}	-V _{GS(th)}	V _{DS} =V _{GS} , I _D =-250μA	1.2	1.75	2.5	V
Drain-Source On-Resistance ^{Note2}	R _{DS(on)}	V _{GS} =-10V, I _D =-3A	--	68	85	mΩ
		V _{GS} =-4.5V, I _D =-2A	--	90	110	mΩ
Forward Transconductance	g _{fs}	V _{DS} =-5V, I _D =-3A	--	8.5	--	S
Dynamic Characteristics						
Input Capacitance	C _{iss}	V _{DS} =-15V, V _{GS} =0V, f =1MHz	--	1137	--	pF
Output Capacitance	C _{oss}		--	76	--	pF
Reverse Transfer Capacitance	C _{rss}		--	50	--	pF
Switching Characteristics						
Turn-on Delay Time	t _{d(on)}	V _{DD} =-15V, I _D =-1A, V _{GS} =-10V, R _G =3.3Ω	--	9.2	--	nS
Turn-on Rise Time	t _r		--	20.1	--	nS
Turn-off Delay Time	t _{d(off)}		--	46.7	--	nS
Turn-off Fall Time	t _f		--	9.4	--	nS
Total Gate Charge	Q _g	V _{DS} =-48V, I _D =-3A, V _{GS} =-4.5V	--	12.1	--	nC
Gate-Source Charge	Q _{gs}		--	2.2	--	nC
Gate-Drain Charge	Q _{gd}		--	6.3	--	nC
Source-Drain Diode Characteristics						
Diode Forward Voltage ^{Note2}	-V _{SD}	V _{GS} =0V, I _S =-1A	--	--	1.2	V
Diode Forward Current ^{Note1,5}	-I _S		--	--	13	A

Note :

- 1.The data tested by surface mounted on a 1 inch² FR-4 board with 2OZ copper.
- 2.The data tested by pulsed , pulse width ≤ 300us , duty cycle ≤ 2%
- 3.The E_{AS} data shows Max. rating . The test condition is V_{DD}=-25V, V_{GS}=-10V, L=0.1mH, I_{AS}=-24A
- 4.The power dissipation is limited by 150°C junction temperature
- 5.The data is theoretically the same as I_D and I_{DM} , in real applications , should be limited by total power dissipation.



Typical Characteristic Curves

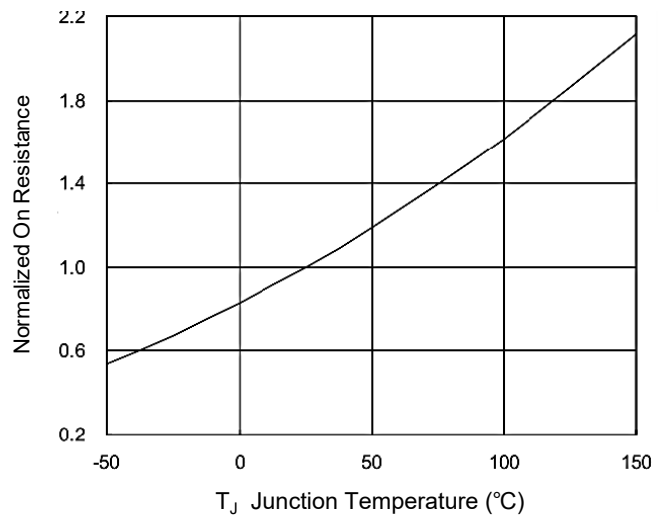
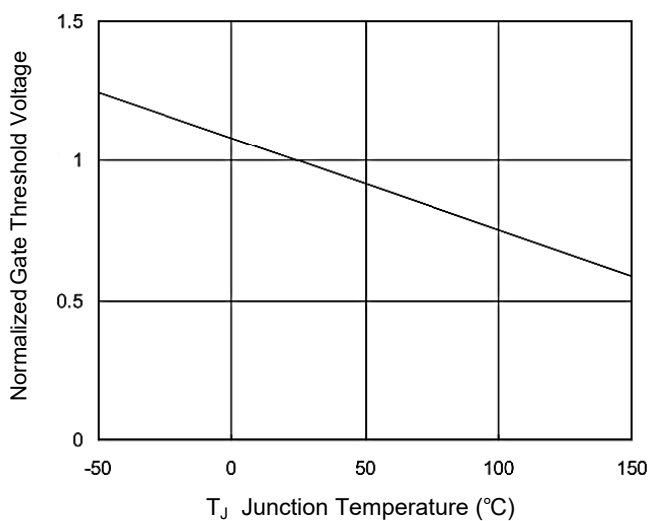
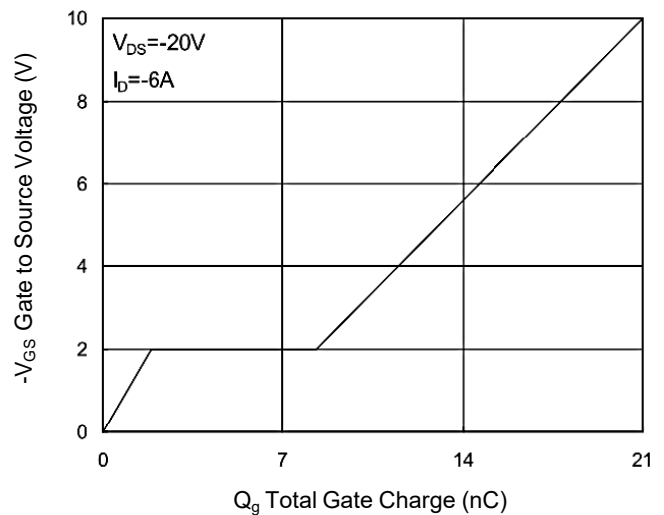
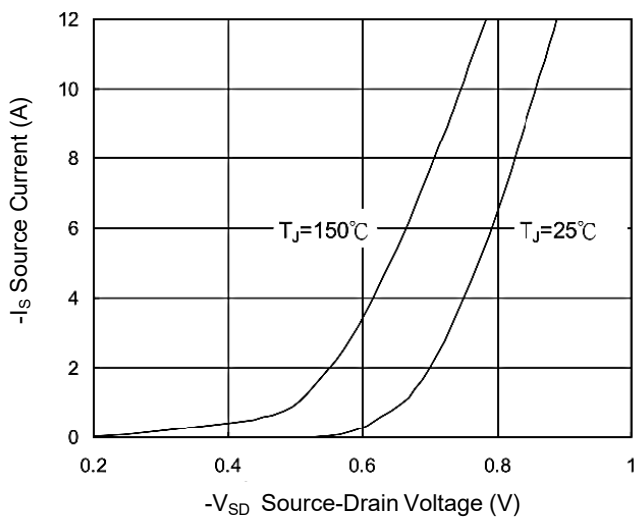
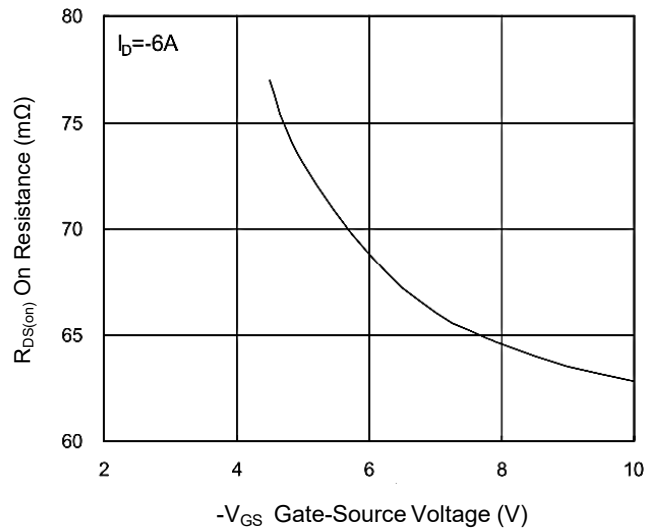
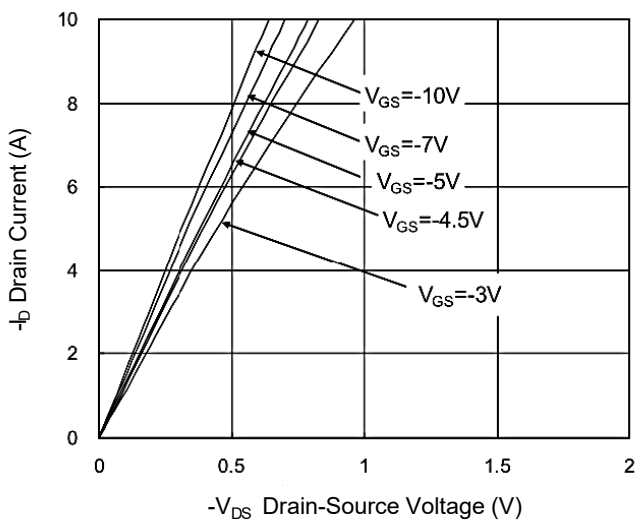



PJM15P60DL

P-Channel Enhancement Mode Power MOSFET

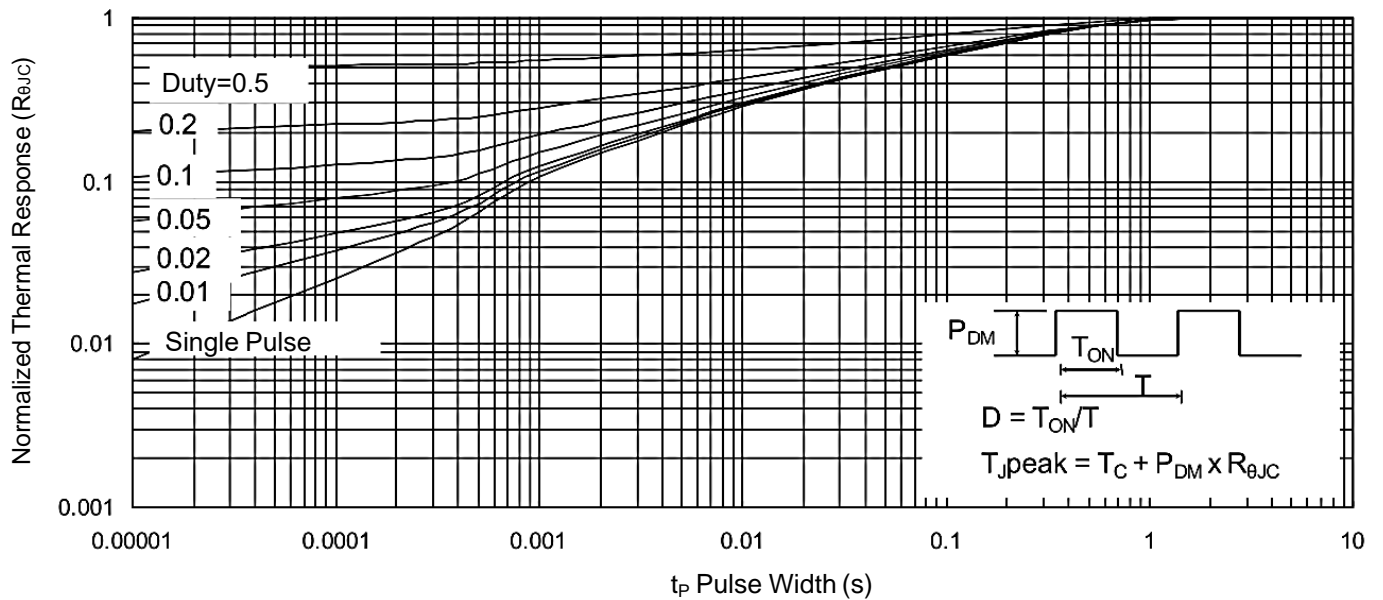
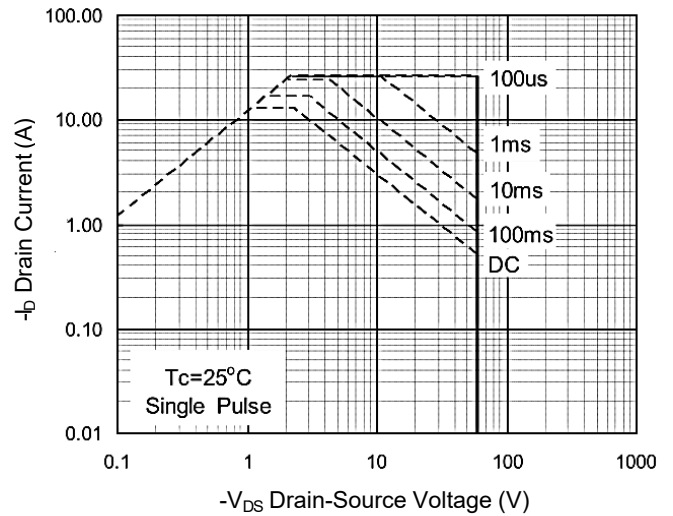
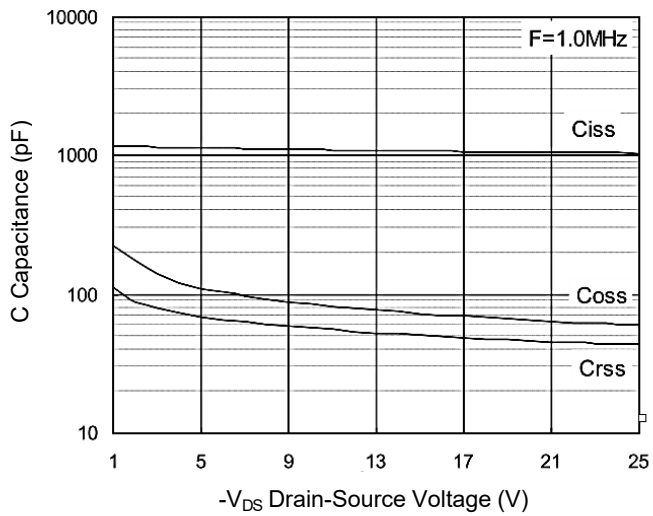



PJM15P60DL

P-Channel Enhancement Mode Power MOSFET

Package Outline

PDFN3x3-8L

Dimensions in mm

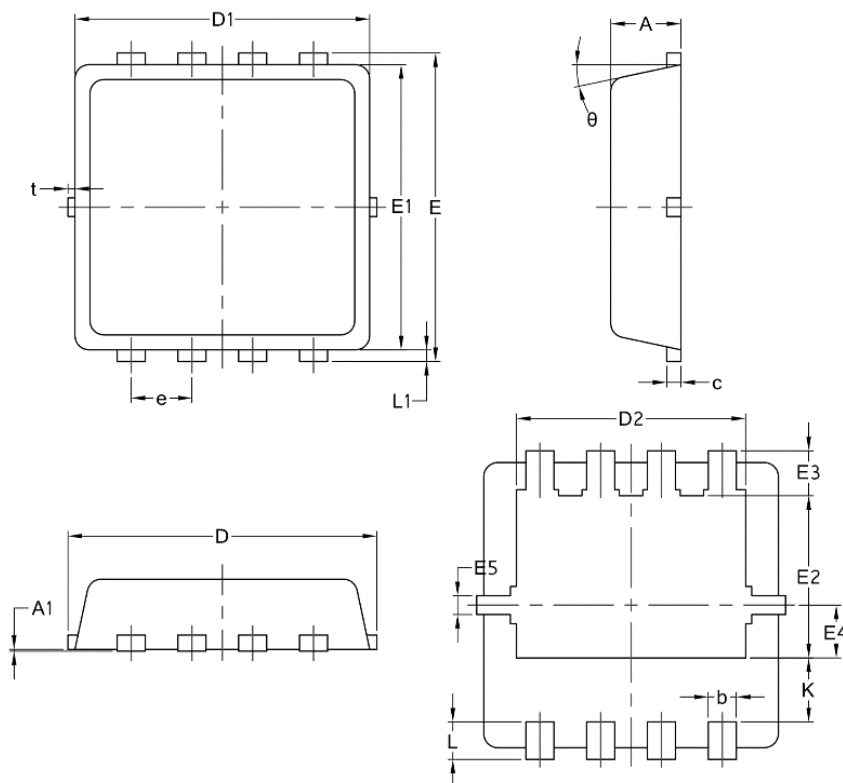

Symbol	Common		
	mm		
	Mim	Nom	Max
A	0.70	0.75	0.85
A1	/	/	0.05
b	0.20	0.30	0.40
c	0.10	0.152	0.25
D	3.15	3.30	3.45
D1	3.00	3.15	3.25
D2	2.29	2.45	2.65
E	3.15	3.30	3.45
E1	2.90	3.05	3.20
E2	1.54	1.74	1.94
E3	0.28	0.48	0.65
E4	0.37	0.57	0.77
E5	0.10	0.20	0.30
e	0.60	0.65	0.70
K	0.59	0.69	0.89
L	0.30	0.40	0.50
L1	0.06	0.125	0.20
t	0	0.075	0.13
Φ	10	12	14