



PJM150H03NTF

N-Channel Enhancement Mode Power MOSFET

Features

- Fast Switching
- Low Gate Charge
- Fast Recovery Body Diode
- $V_{DS} = 1500V, I_D = 3A$
 $R_{DS(on)} < 6.5\Omega @ V_{GS} = 10V$

Applications

- Adaptor
- Charger
- SMPS Standby Power

TO-220F

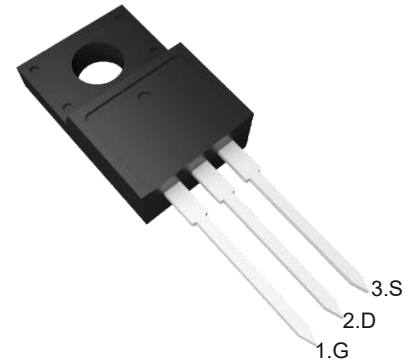

1.Gate 2.Drain 3.Source

Schematic diagram

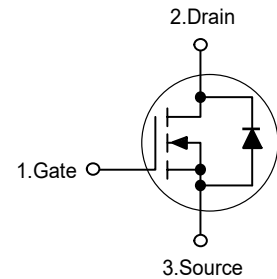

Absolute Maximum Ratings

Ratings at 25°C ambient temperature unless otherwise specified.

Parameter	Symbol	Value	Unit
Drain-Source Voltage	V_{DS}	1500	V
Gate-Source Voltage	V_{GS}	± 30	V
Drain Current-Continuous	I_D	3	A
Drain Current-Pulsed ^{Note1}	I_{DM}	12	A
Single Pulse Avalanche Energy	E_{AS}	130	mJ
Maximum Power Dissipation	P_D	30	W
Junction Temperature	T_J	150	°C
Storage Temperature Range	T_{STG}	-55 to +150	°C
Maximum Temperature For Soldering	T_L	300	°C
Leads At 0.63 In(1.6mm) From Case For 10 seconds, Package Body For 10 Seconds	T_{PAK}	260	°C

Thermal Characteristics

Maximum Junction-to-Case ^{Note2}	$R_{\theta JC}$	4.17	°C/W
Maximum Junction-to-Ambient ^{Note2}	$R_{\theta JA}$	62.5	°C/W



PJM150H03NTF

N-Channel Enhancement Mode Power MOSFET

Electrical Characteristics

(Ta=25°C unless otherwise specified)

Parameter	Symbol	Test Condition	Min.	Typ.	Max.	Unit
Static Characteristics						
Drain-Source Breakdown Voltage	$V_{(BR)DSS}$	$V_{GS}=0V, I_D=250\mu A$	1500	--	--	V
Drain-Source Leakage Current	I_{DSS}	$V_{DS}=1500V, V_{GS}=0V$	--	--	10	μA
Gate-Body Leakage Current	I_{GSS}	$V_{GS}=\pm 30V, V_{DS}=0V$	--	--	± 100	nA
Gate Threshold Voltage ^{Note3}	$V_{GS(th)}$	$V_{DS}=V_{GS}, I_D=250\mu A$	2.5	--	4.5	V
Drain-Source On-Resistance ^{Note3}	$R_{DS(on)}$	$V_{GS}=10V, I_D=1.5A$	--	--	6.5	Ω
Forward Transconductance ^{Note3}	g_{FS}	$V_{DS}=15V, I_D=10A$	--	24	--	S
Dynamic Characteristics						
Input Capacitance	C_{iss}	$V_{DS}=25V, V_{GS}=0V, f=1MHz$	--	1900	--	pF
Output Capacitance	C_{oss}		--	100	--	pF
Reverse Transfer Capacitance	C_{rss}		--	13	--	pF
Switching Characteristics						
Turn-on Delay Time	$t_{d(on)}$	$V_{DD}=800V, V_{GS}=10V$ $I_D=3A, R_G=10\Omega$	--	33	--	nS
Turn-on Rise Time	t_r		--	16	--	nS
Turn-off Delay Time	$t_{d(off)}$		--	58	--	nS
Turn-off Fall Time	t_f		--	28	--	nS
Total Gate Charge	Q_g	$V_{DD}=800V, V_{GS}=10V, I_D=3A$	--	9.5	--	nC
Gate-Source Charge	Q_{gs}		--	15	--	nC
Gate-Drain Charge	Q_{gd}		--	5.5	--	nC
Source-Drain Diode Characteristics						
Diode Forward Voltage ^{Note3}	V_{SD}	$V_{GS}=0V, I_S=3A$	--	--	5	V
Diode Forward Current ^{Note2}	I_{SD}		--	--	3	A

Note: 1. Repetitive Rating: Pulse width limited by maximum junction temperature.

2. Surface Mounted on FR4 Board, $t \leq 10$ sec.

3. Pulse Test: Pulse width < 380 μ s, duty cycle < 2%.



PJM150H03NTF

N-Channel Enhancement Mode Power MOSFET

Typical Characteristic Curves

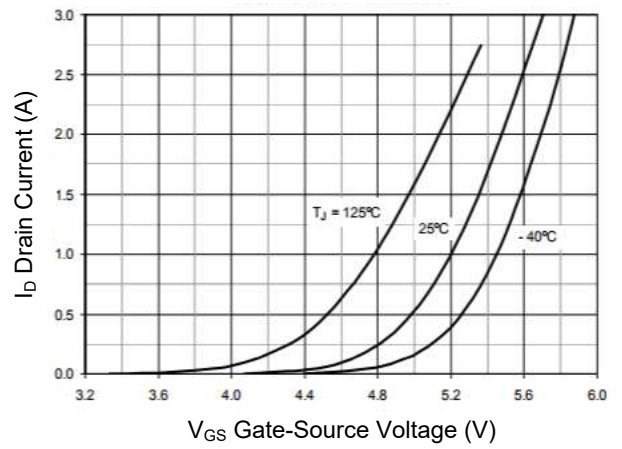
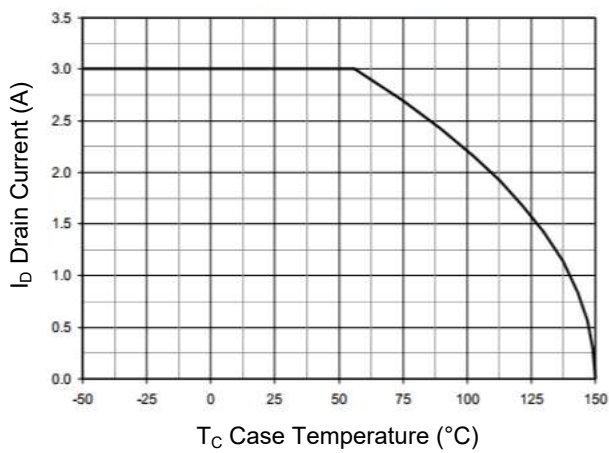
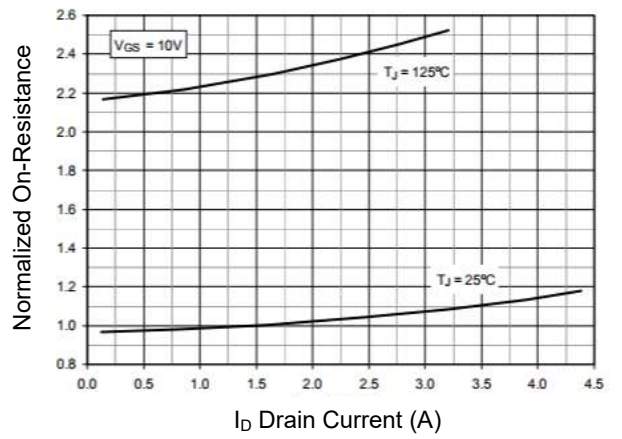
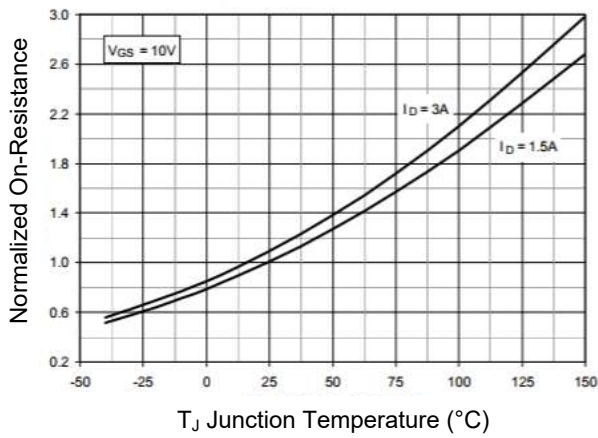
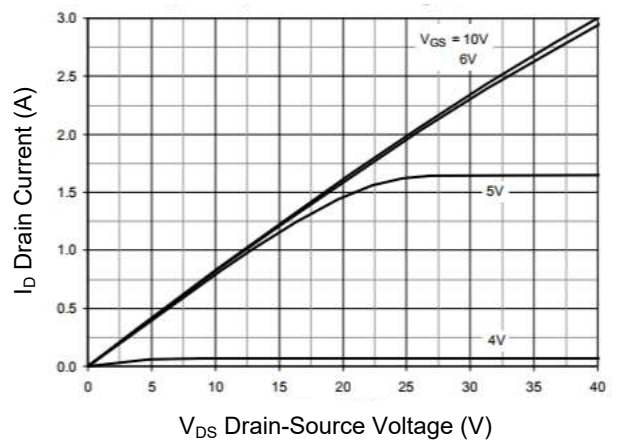
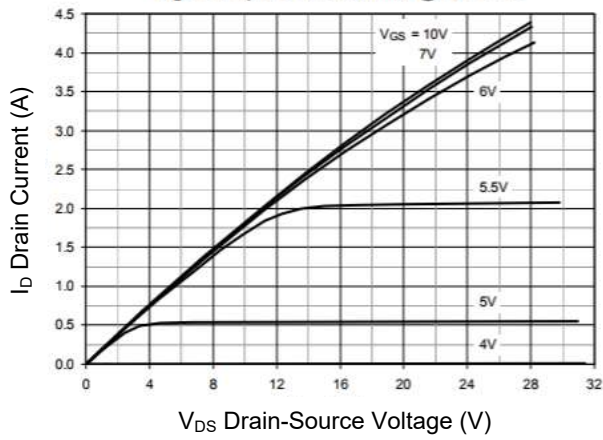



PJM150H03NTF

N-Channel Enhancement Mode Power MOSFET

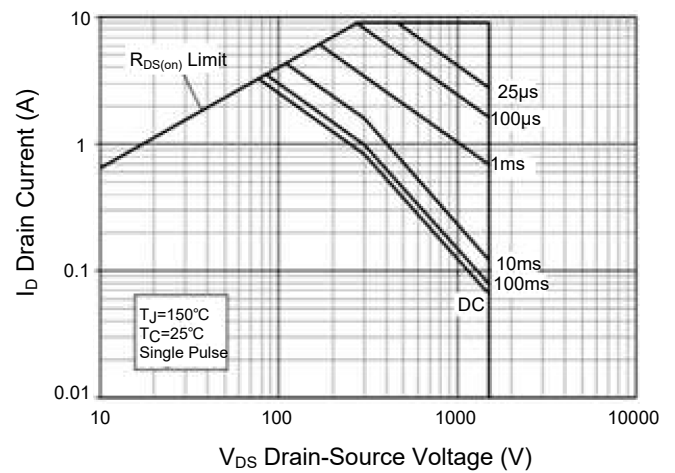
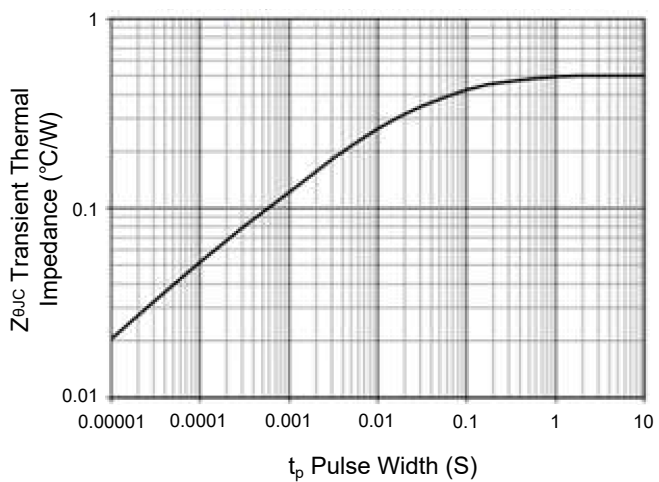
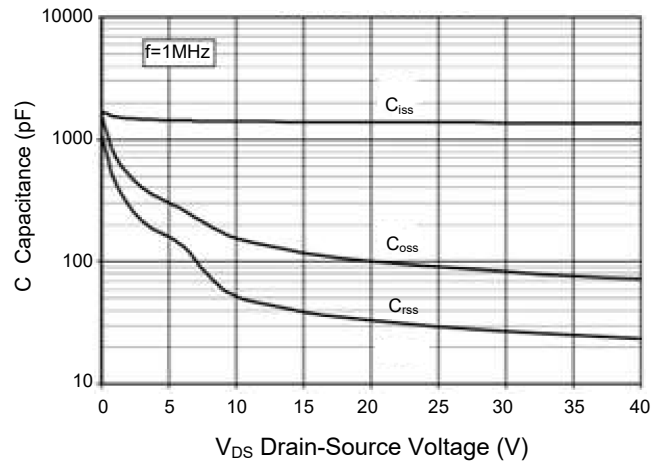
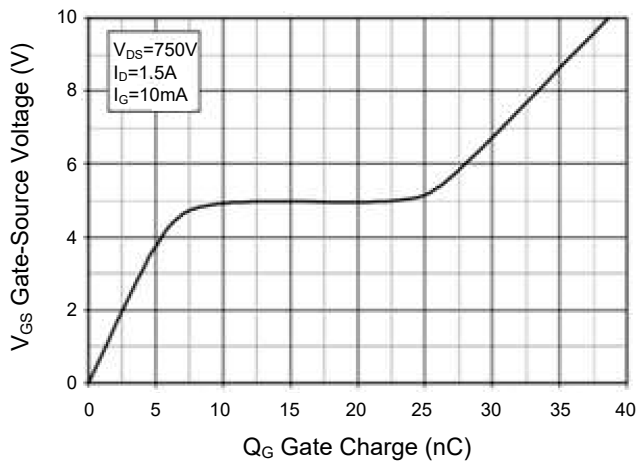
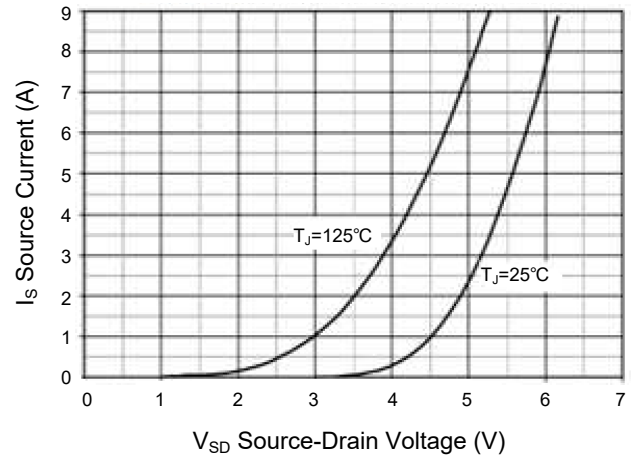
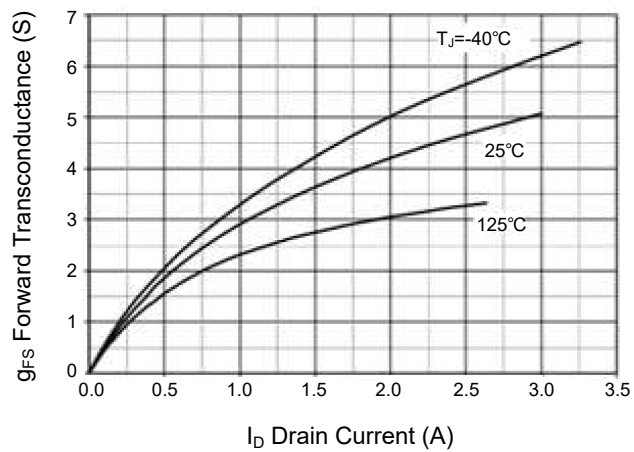



PJM150H03NTF

N-Channel Enhancement Mode Power MOSFET

Package Outline

TO-220F

Dimensions in mm

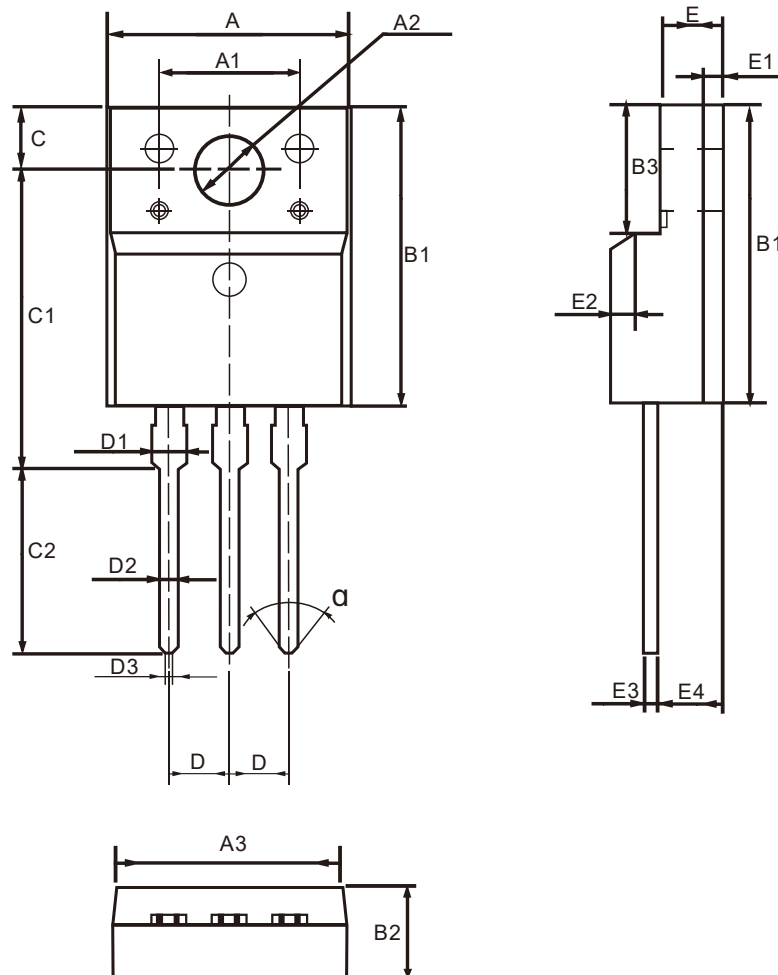

TO-220F Package Dimensions

UNIT: mm

SYMBOL	min	nom	max	SYMBOL	min	nom	max
A	9.80		10.60	D		2.54	
A1		7.00		D1	1.15		1.55
A2	2.90		3.40	D2	0.60		1.00
A3	9.10		9.90	D3	0.20		0.50
B1	15.40		16.40	E	2.24		2.84
B2	4.35		4.95	E1		0.70	
B3	6.00		7.40	E2		1.0×45°	
C	3.00		3.70	E3	0.35		0.65
C1	15.00		17.00	E4	2.30		3.30
C2	8.80		10.80	α (度)		30°	