

### Features

- For Switching and AF Amplifier Applications
- Halogen and Antimony Free
- Moisture Sensitivity Level 1

### Equivalent Circuit

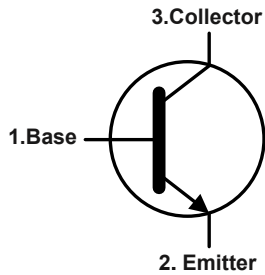

### DFN1x0.6-3L

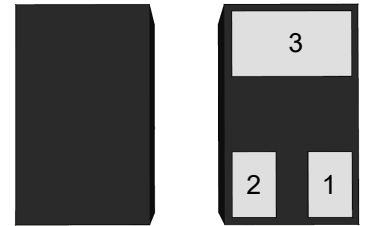

(Top View) (Bottom View)

1.Base 2.Emitter 3.Collector

### Marking Code :

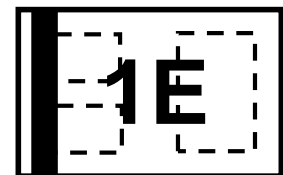

### Absolute Maximum Ratings

Ratings at 25°C ambient temperature unless otherwise specified.

Parameter	Symbol	Value	Unit
Collector Base Voltage	$V_{CBO}$	60	V
Collector Emitter Voltage	$V_{CEO}$	40	V
Emitter Base Voltage	$V_{EBO}$	6	V
Collector Current	$I_C$	200	mA
Maximum Power Dissipation	$P_D$	250	mW
Junction Temperature	$T_J$	150	°C
Storage Temperature Range	$T_{STG}$	-55 to +150	°C



### Electrical Characteristics (T<sub>A</sub>=25°C)

Parameter	Symbol	Min.	Max.	Unit
DC Current Gain at V <sub>CE</sub> = 1 V, I <sub>C</sub> = 0.1 mA at V <sub>CE</sub> = 1 V, I <sub>C</sub> = 1 mA at V <sub>CE</sub> = 1 V, I <sub>C</sub> = 10 mA at V <sub>CE</sub> = 1 V, I <sub>C</sub> = 50 mA at V <sub>CE</sub> = 1 V, I <sub>C</sub> = 100 mA	H <sub>FE</sub>	40 70 100 60 30	-- -- 300 -- --	--
Collector Base Cutoff Current at V <sub>CB</sub> = 30V	I <sub>CBO</sub>	--	50	nA
Emitter Base Cutoff Current at V <sub>EB</sub> = 6 V	I <sub>EBO</sub>	--	50	nA
Collector Base Breakdown Voltage at I <sub>C</sub> = 10 μA	V <sub>(BR)CBO</sub>	60	--	V
Collector Emitter Breakdown Voltage at I <sub>C</sub> = 1 mA	V <sub>(BR)CEO</sub>	40	--	V
Emitter Base Breakdown Voltage at I <sub>E</sub> = 10 μA	V <sub>(BR)EBO</sub>	6	--	V
Collector Emitter Saturation Voltage at I <sub>C</sub> = 10 mA, I <sub>B</sub> = 1 mA at I <sub>C</sub> = 50 mA, I <sub>B</sub> = 5 mA	V <sub>CE(sat)</sub>	-- --	0.2 0.3	V
Base Emitter Saturation Voltage at I <sub>C</sub> = 10 mA, I <sub>B</sub> = 1 mA at I <sub>C</sub> = 50 mA, I <sub>B</sub> = 5 mA	V <sub>BE(sat)</sub>	0.65 --	0.85 0.95	V
Transition Frequency at V <sub>CE</sub> = 20 V, I <sub>C</sub> = 10 mA, f = 100 MHz	F <sub>T</sub>	300	--	MHz
Output Capacitance at V <sub>CB</sub> = 5 V, I <sub>E</sub> = 0, f = 1 MHz	C <sub>ob</sub>	--	4	pF



### Typical Characteristic Curves

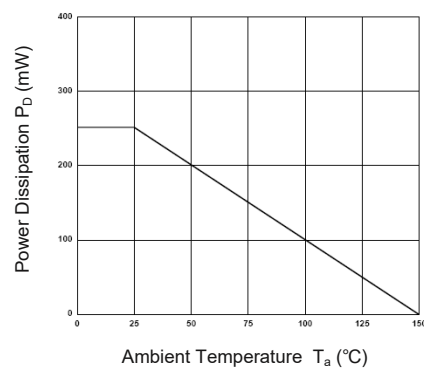
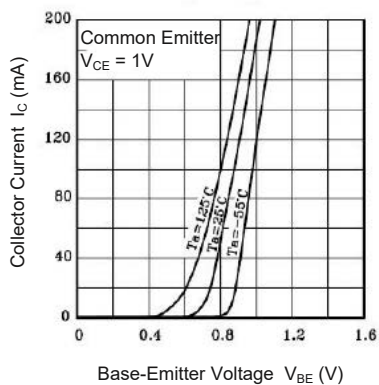
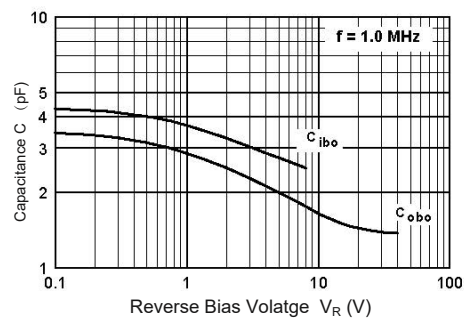
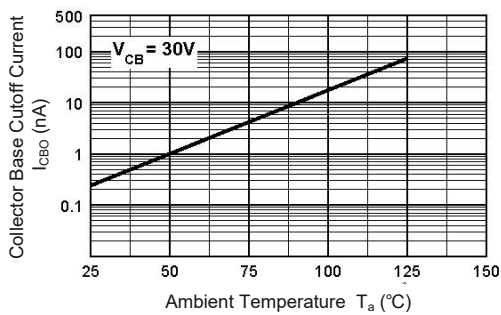
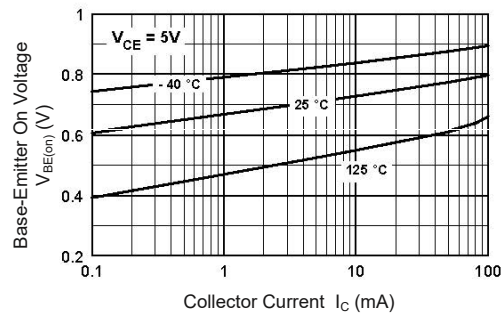
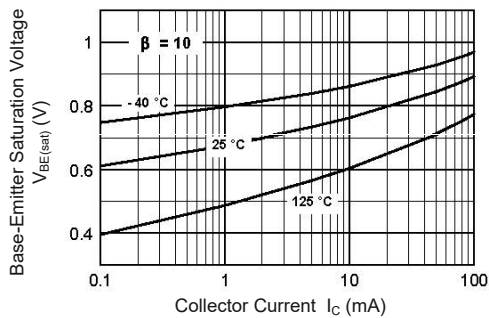
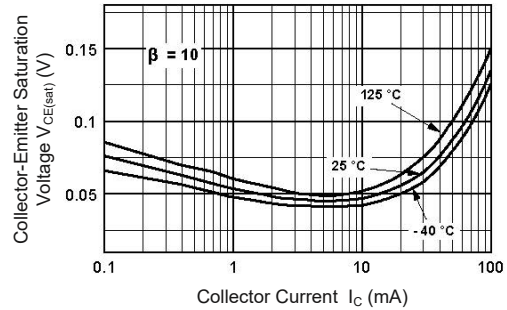
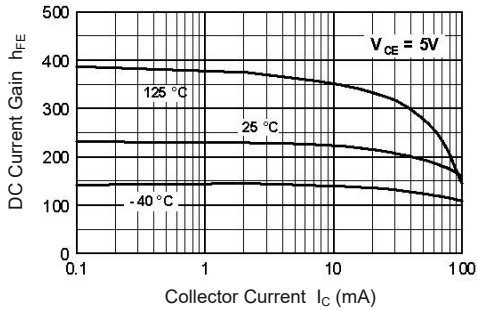

### Package Outline

DFN1x0.6-3L-0009

Dimensions in mm

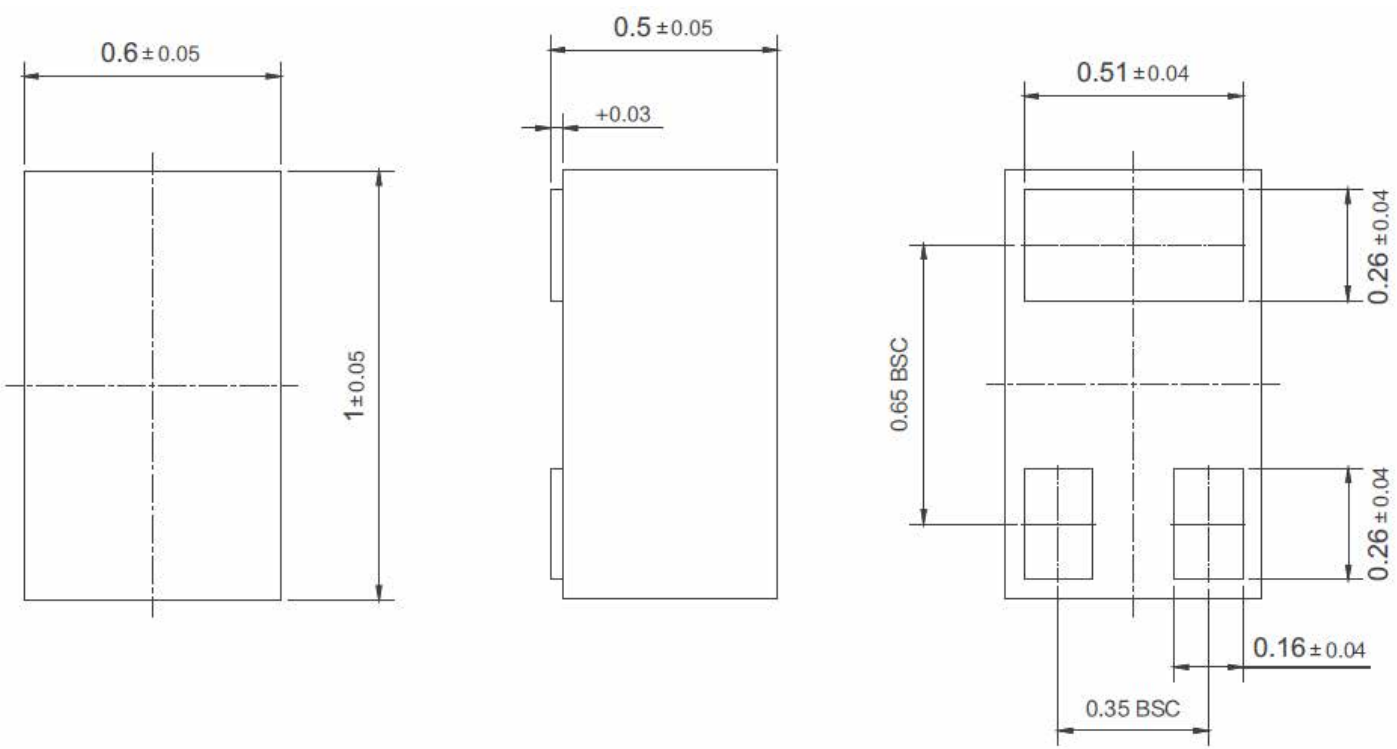

### Ordering Information

Device	Package	Shipping
MMBT3904DC	DFN1x0.6-3L	10,000PCS/Reel&7inches

### Conditions of Soldering and Storage

#### ◆ Recommended condition of reflow soldering

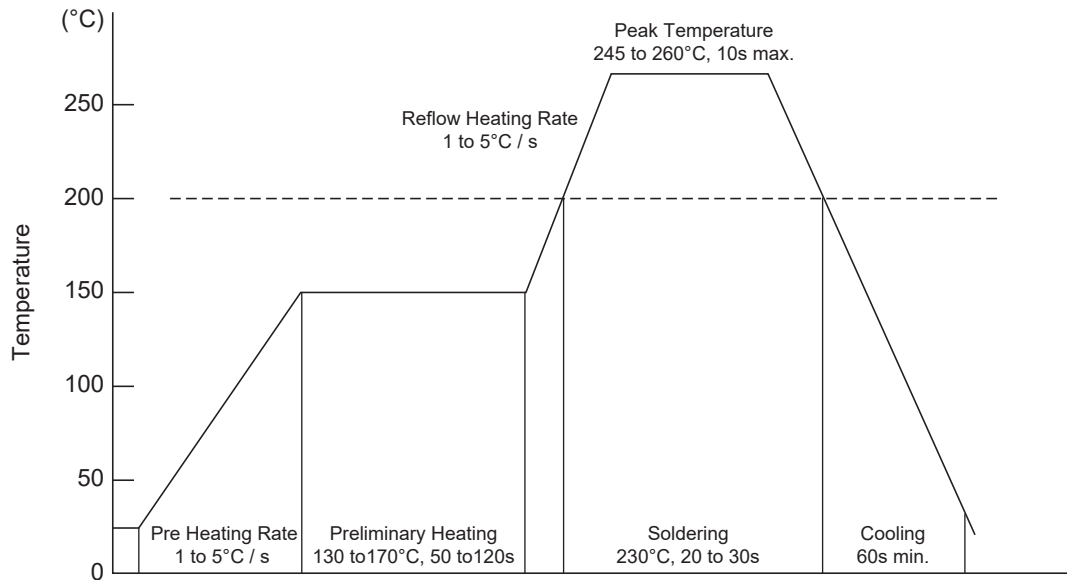

Recommended peak temperature is over 245°C. If peak temperature is below 245°C, you may adjust the following parameters:

- Time length of peak temperature (longer)
- Time length of soldering (longer)
- Thickness of solder paste (thicker)

#### ◆ Conditions of hand soldering

- Temperature: 300°C
- Time: 3s max.
- Times: one time

#### ◆ Storage conditions

- **Temperature**  
5 to 40°C
- **Humidity**  
30 to 80% RH
- **Recommended period**  
One year after manufacturing

### Package Specifications

- The method of packaging

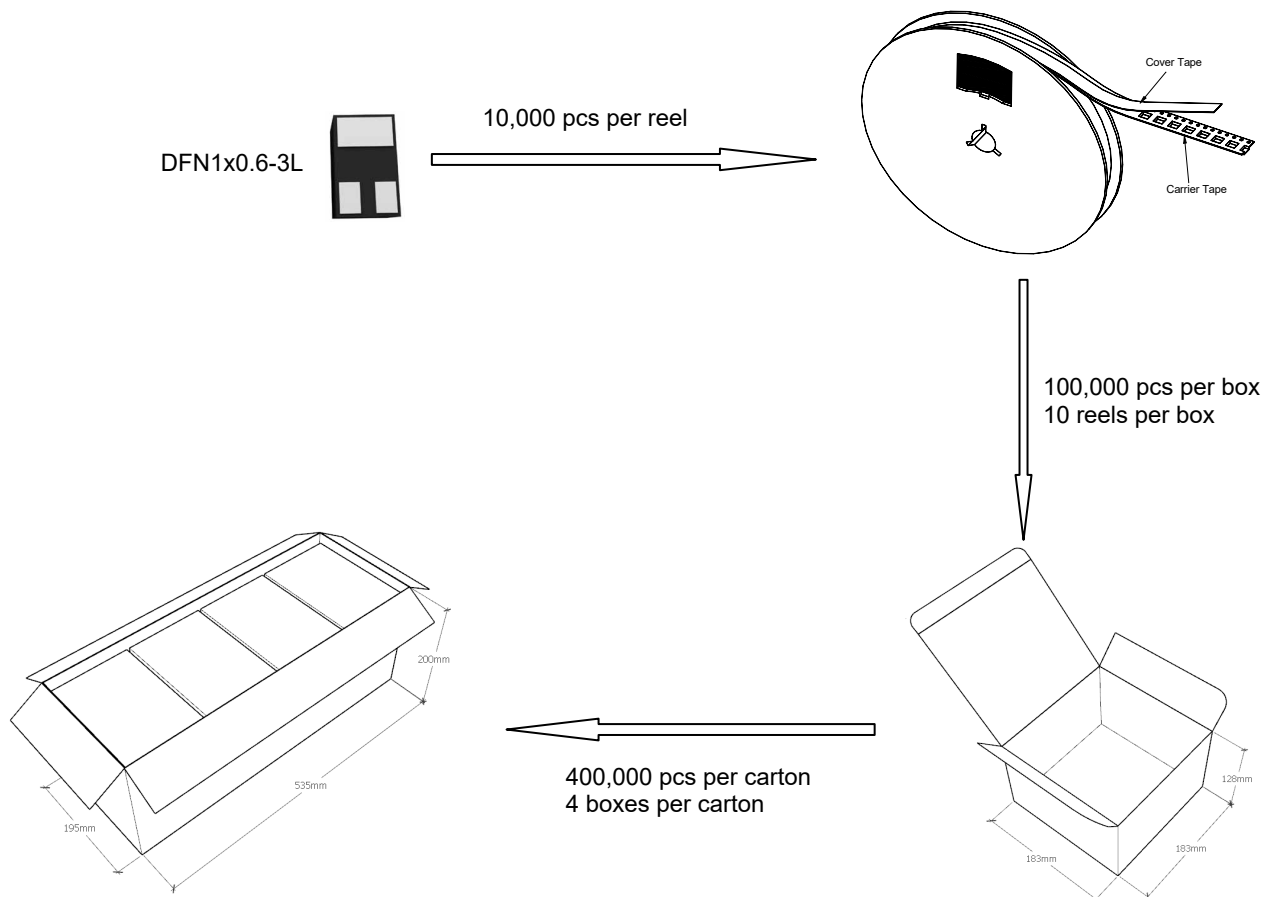

### ◆ reel data

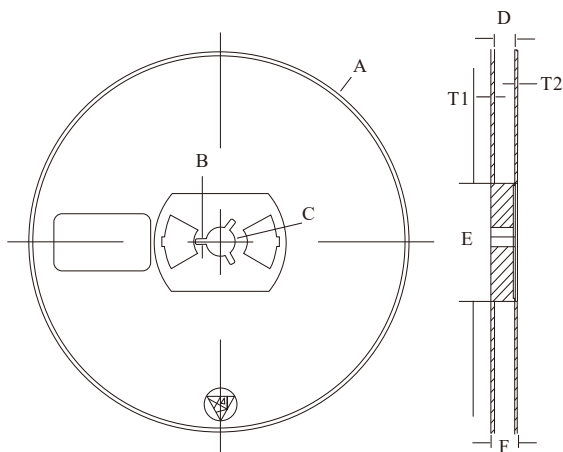

Symbol	Value (unit: mm)
A	Ø 177.8±1
B	2.7±0.2
C	Ø 13.5±0.2
E	Ø 54.5±0.2
F	12.3±0.3
D	9.6+2/-0.3
T1	1.0±0.2
T2	1.2±0.2

◆ Embossed tape data

