



ES2KB-PJ

Surface Mount Superfast Recovery Rectifiers

Features

- Glass Passivated Chip Junction
- For Surface Mounted Applications
- Low profile package
- Superfast reverse recovery time

SMB

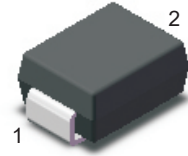

1.Cathode  2.Anode

Marking Code: ES2K

Maximum Ratings and Electrical Characteristics

Ratings at 25°C ambient temperature unless otherwise specified. Single phase half-wave 60 Hz, resistive or inductive load, for capacitive load current derate by 20 %.

Parameter	Symbols	Value	Units
Maximum Repetitive Peak Reverse Voltage	V_{RRM}	800	V
Maximum RMS Voltage	V_{RMS}	560	V
Maximum DC Blocking Voltage	V_{DC}	800	V
Maximum Average Forward Rectified Current at $T_C = 125^\circ\text{C}$	$I_{F(AV)}$	2.0	A
Peak Forward Surge Current 8.3 ms Single Half Sine Wave Superimposed on Rated Load	I_{FSM}	60	A
Maximum Instantaneous Forward Voltage at 2 A	V_F	1.70	V
Maximum DC Reverse Current at Rated DC Blocking Voltage $T_A = 25^\circ\text{C}$ $T_A = 125^\circ\text{C}$	I_R	5 100	μA
Typical Junction Capacitance ^{Note1}	C_j	40	pF
Typical Thermal Resistance ^{Note2}	$R_{\theta JA}$	60	$^\circ\text{C/W}$
Maximum Reverse Recovery Time ^{Note3}	T_{rr}	35	nS
Junction Temperature	T_J	150	$^\circ\text{C}$
Storage Temperature Range	T_{STG}	-55 to +150	$^\circ\text{C}$

Note:

1. Measured at 1 MHz and applied reverse voltage of 4 V D.C
2. P.C.B. mounted with 2.0" X 2.0" (5 X 5 cm) copper pad areas.
3. Measured with $I_F = 0.5\text{ A}$, $I_R = 1\text{ A}$, $I_{rr} = 0.25\text{ A}$.



Typical Characteristic Curves

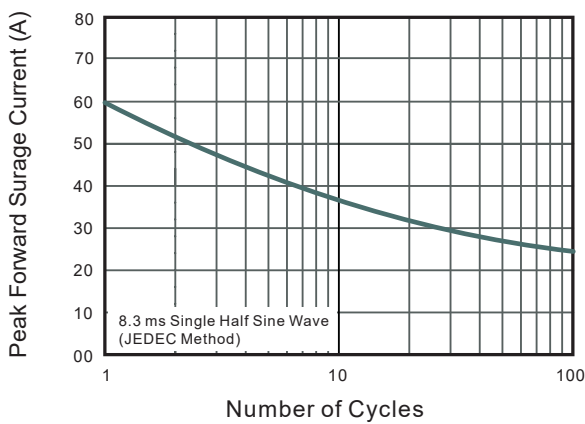
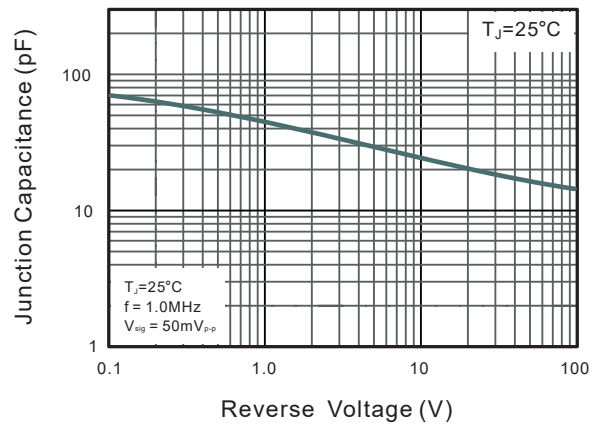
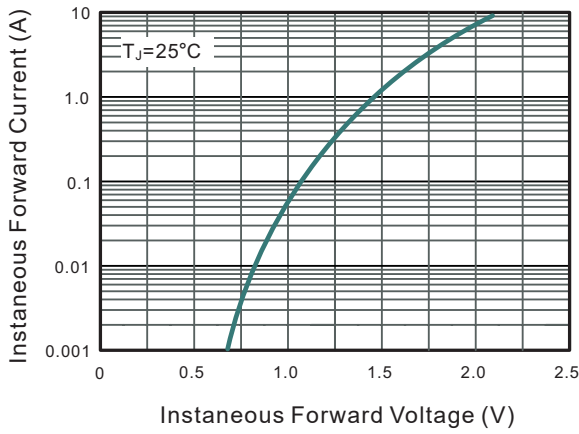
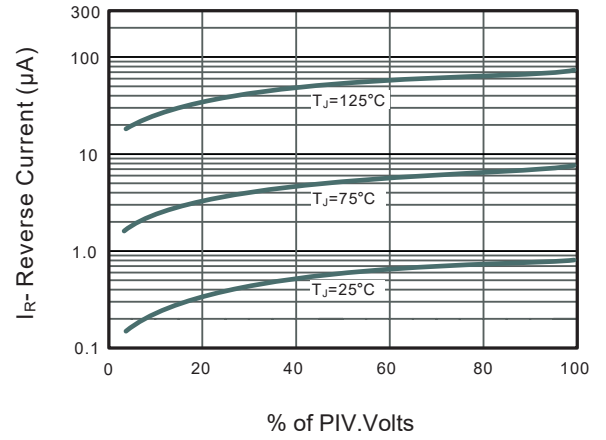
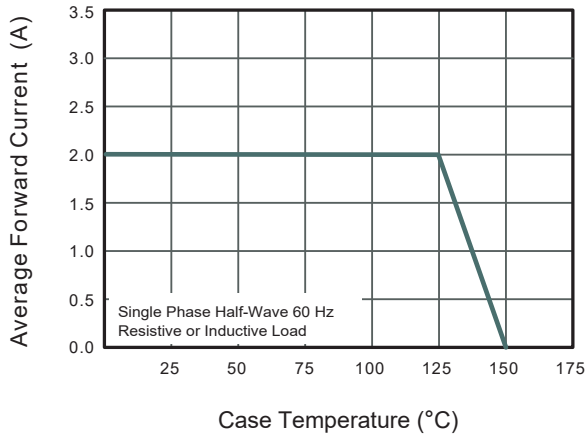



Package Outline

SMB

Dimensions in mm

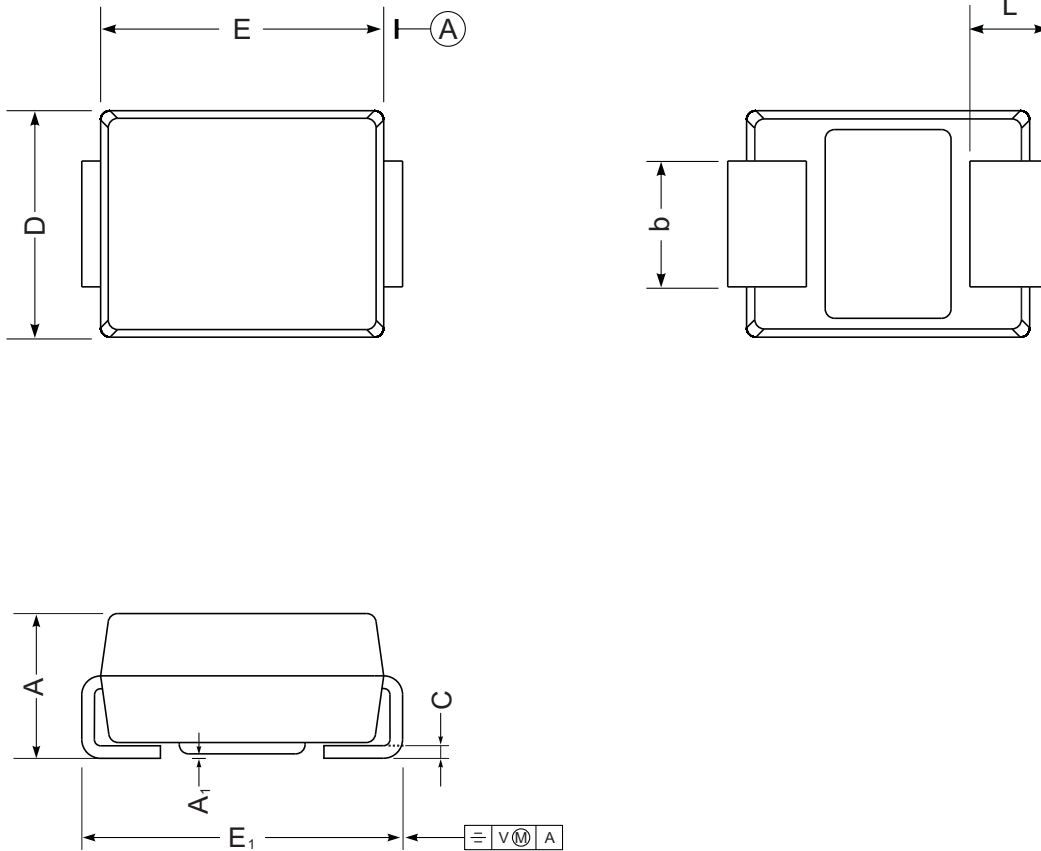

UNIT		A	E	D	E1	A1	L	C	b
mm	max	2.44	4.70	3.94	5.59	0.20	1.5	0.305	2.2
	min	2.13	4.06	3.3	5.08	0.05	0.8	0.152	1.9
mil	max	96	185	155	220	7.9	59	12	87
	min	84	160	130	200	2.0	32	6	75